

THIS DOCUMENT PREPARED  
BY AND RETURN TO:

THOMAS M. JENKS, ESQUIRE  
PAPPAS METCALF JENKS & MILLER, P.A.  
200 WEST FORSYTH STREET, SUITE 1400  
JACKSONVILLE, FLORIDA 32202-4327

Doc# 2002011036  
Book: 10308  
Pages: 2308 - 2389  
Filed & Recorded  
01/11/2002 09:45:18 AM  
JIM FULLER  
CLERK CIRCUIT COURT  
DUVAL COUNTY  
TRUST FUND \$ 41.50  
RECORDING \$ 329.00

**DECLARATION OF CONDOMINIUM**  
**FOR**  
**CITIHOMES AT SAN MARCO CONDOMINIUM**

82

INDEX TO  
DECLARATION OF CONDOMINIUM  
FOR  
CITIHMES AT SAN MARCO CONDOMINIUM

I.	SUBMISSION TO CONDOMINIUM OWNERSHIP. ....	1
II.	NAME AND ADDRESS. ....	1
III.	THE LAND. ....	1
IV.	DESCRIPTION OF CONDOMINIUM PROPERTY. ....	1
V.	DEFINITION OF UNITS AND COMMON ELEMENTS. ....	2
	A. Units. ....	2
	B. Common Elements. ....	2
	C. Limited Common Elements. ....	3
VI.	APPURTENANCES TO UNITS. ....	3
VII.	COMMON EXPENSES AND COMMON SURPLUS. ....	5
VIII.	THE ASSOCIATION. ....	5
	A. Operation of the Condominium. ....	5
	B. Power to Grant Easements. ....	5
IX.	BYLAWS OF ASSOCIATION. ....	5
X.	VOTING RIGHTS OF UNIT OWNERS. ....	6
XI.	AMENDMENT OF DECLARATION. ....	6
	A. Notice. ....	6
	B. Proposal. ....	6
	C. Adoption. ....	6
	D. Form of Proposed Amendment. ....	7
	E. Effective Date and Recording Evidence of Amendment. ....	7
	F. Amendment to Correct Omission or Error in Condominium Documents. ....	8
	G. Amendment by Developer ....	8

	H.	Amendments Relating to Surface Water or Stormwater Management System. ....	8
XII.		<b>MAINTENANCE, REPAIRS AND REPLACEMENTS.</b> .....	8
	A.	Units. ....	8
	B.	Common Elements. ....	9
	C.	Limited Common Elements. ....	9
XIII.		<b>INSURANCE</b> .....	10
	A.	Duty and Authority to Obtain. ....	10
	B.	Required Coverage. ....	10
	C.	Optional Coverage. ....	11
	D.	Premiums. ....	11
	E.	Assured. ....	11
	F.	Insurer. ....	11
	G.	Insurance Trustee. ....	11
	H.	Application of Insurance Proceeds. ....	12
	I.	Deposits to Insurance Trustee After Damage. ....	13
XIV.		<b>RECONSTRUCTION OR REPAIR AFTER CASUALTY.</b> .....	13
	A.	Residential Buildings. ....	13
	B.	Common Elements. ....	14
	C.	Certificate. ....	14
	D.	Plans and Specifications. ....	14
	E.	Responsibility. ....	14
	F.	Construction Funds. ....	14
XV.		<b>USE RESTRICTIONS.</b> .....	16
	A.	Units. ....	16
	B.	Common Elements and Limited Common Elements. ....	16
	C.	Nuisances. ....	16
	D.	Lawful Use. ....	16
	E.	Regulations. ....	16
	F.	Proviso. ....	16
	G.	Rights of Developer. ....	17
XVI.		<b>COMPLIANCE AND DEFAULT.</b> .....	17
	A.	Negligence. ....	17
	B.	Costs and Attorneys' Fees. ....	17

	C.	Fines, etc. ....	17
	D.	No Waiver of Rights. ....	17
XVII .		<b>ASSESSMENTS: LIABILITY, LIEN AND ENFORCEMENT. ....</b>	<b>18</b>
	A.	Determination of Assessments. ....	18
	B.	Time for Payment. ....	18
	C.	Annual Budget. ....	18
	D.	Reserve Fund. ....	19
	E.	General Operating Reserve. ....	19
	F.	Use of Association Funds. ....	19
	G.	Delinquency or Default. ....	19
	H.	Personal Liability of Unit Owner. ....	20
	I.	Liability Not Subject to Waiver. ....	20
	J.	Lien for Assessment. ....	20
	K.	Recording and Priority of Lien. ....	20
	L.	Effect of Foreclosure or Judicial Sale. ....	20
	M.	Effect of Voluntary Transfer. ....	21
	N.	Commencement of Assessments. ....	21
XVIII.		<b>REGISTRY OF OWNERS AND MORTGAGEES. ....</b>	<b>21</b>
XIX.		<b>ALTERATIONS OF AND IMPROVEMENTS TO UNITS AND COMMON ELEMENTS. ....</b>	<b>22</b>
	A.	Units and Limited Common Elements. ....	22
	B.	Common Elements. ....	23
XX.		<b>TERMINATION. ....</b>	<b>23</b>
	A.	Destruction. ....	23
	B.	Agreement. ....	23
	C.	Certificate. ....	24
	D.	Shares of Owners After Termination. ....	24
	E.	Amendment. ....	24
XXI.		<b>CONDEMNATION. ....</b>	<b>24</b>
	A.	General. ....	24
	B.	Common Elements. ....	24
	C.	Condemnation of a Unit or Part of a Unit. ....	25
	D.	Notice to Mortgagees. ....	25
XXII.		<b>RIGHTS OF DEVELOPER TO SELL UNITS. ....</b>	<b>25</b>



XXIII. RIGHTS OF INSTITUTIONAL MORTGAGEES. . . . . 25

XXIV. MISCELLANEOUS. . . . . 27

A. Severability. . . . . 27

B. Applicability of Declaration of Condominium. . . . . 27

C. Construction. . . . . 27

D. Assignment by Developer. . . . . 27

E. Parties Bound. . . . . 27

**Exhibits**

- A Legal Description of Land Submitted to Condominium Form of Ownership
- B Percentage of Undivided Interest in Common Elements and Common Expense
- C Plot Plan and Survey
- D Floor Plan
- E Articles of Incorporation of Citihomes at San Marco Condominium Association, Inc.
- F Bylaws of Citihomes at San Marco Condominium Association, Inc.

**DECLARATION OF CONDOMINIUM  
FOR  
CITIHMES AT SAN MARCO CONDOMINIUM**

**THIS DECLARATION OF CONDOMINIUM FOR CITIHOMES AT SAN MARCO CONDOMINIUM** is made this \_\_\_ day of \_\_\_\_\_, 2001, by **DUNSFORD TERRACE APARTMENTS, LLC**, a Georgia limited liability company ("Developer"), the owner of fee simple title to the land described in Article III hereof. The term "Developer" shall mean and refer to the entity executing this Declaration, its successor, grantees, assigns, nominees and designees. In the event the holder of any mortgage executed by Developer obtains title to all or any portion of the Condominium Property by foreclosure or deed in lieu thereof, such mortgagee shall become the Developer only if it so elects, by written notice to the Board of Directors of the Association described by Article VIII hereof, but in any event such mortgagee may assign its rights as the Developer to any third party who acquires title to all or a portion of the Condominium Property from the mortgagee. In any event, any subsequent Developer shall not be liable for any defaults or obligations incurred by any prior Developer, except as same are expressly assumed by the subsequent Developer.

**I. SUBMISSION TO CONDOMINIUM OWNERSHIP.**

Developer hereby submits to the condominium form of ownership and use, the land described in Article III hereof, the improvements now and hereafter situated thereon and the easements and rights appurtenant thereto ("Condominium" or "Condominium Property") pursuant to Chapter 718, *Florida Statutes*, as amended, to the date hereof ("Condominium Act").

**II. NAME AND ADDRESS.**

The name by which this condominium is to be identified is CITIHOMES AT SAN MARCO CONDOMINIUM. The street address is 2043 Dunsford Terrace, Jacksonville, Florida, 32207.

**III. THE LAND.**

The land submitted to condominium ("Land") is situated in Duval County, Florida, and is described by Exhibit "A" attached hereto and made a part hereof and consists of a parcel of real property upon which are and will be situated residential improvements which are submitted hereby to condominium ownership. A survey of the Land is attached hereto and made a part hereof as part of Exhibit "C".

**IV. DESCRIPTION OF CONDOMINIUM PROPERTY.**

A graphic description of the building in which the Units are located, including an identification of each Unit (as defined in the Condominium Act and herein) by number is attached

hereto and made a part hereof as Exhibit "D". For all type "A" and "B" units as designated in Exhibit "D", there are four (4) optional floor plan layouts from which each initial purchaser of a Unit may choose. These options are illustrated in Exhibit "D". A survey of the Land and plat of improvements located upon the Land is attached hereto and made a part hereof as Exhibit "C". The Condominium Property consists of one (1) building, containing thirty (30) Units and Common Elements, as those terms are herein defined.

V. DEFINITION OF UNITS AND COMMON ELEMENTS.

The Condominium will consist of "Units" and "Common Elements" as those terms are herein defined.

A. Units. The term "Units" as used herein shall mean and comprise the separate residential dwellings in the Condominium which are located and individually described in Exhibits "C" and "D" hereto excluding, however:

1. all spaces and improvements lying beneath the undercoated and/or unfinished inner surfaces of the perimeter walls and floors and above the lowest horizontal plane of the upper structural elements of each Unit;

2. all spaces and improvements lying beneath the undecorated and/or unfinished inner surface of all interior columns, bearing walls and/or bearing partitions; and

3. all glass and other transparent and/or translucent material, insect screens and screening in windows and doors and the material covering other openings in the exterior walls of Units shall be construed to be within the boundaries or limits and part of the Unit exclusively served by such windows, doors and other openings. All heating and air conditioning equipment and associated ducts, wiring, thermostats, conduits and related fixtures, and all water and sewer pipes and plumbing fixtures, that exclusively serve a Unit shall be considered to be a part of such Unit.

B. Common Elements. The term "Common Elements" as used herein shall mean and comprise all of the real property and improvements of the Condominium except the Units including, without limitation:

1. Easements through Units for conduits, pipes, ducts, vents, plumbing, wiring and other facilities, equipment and/or fixtures for the furnishing of utility services, heating and cooling and/or ventilation to Units and Common Elements;

2. Easements of support in every portion of a Unit which contribute to the support of other Units and/or Common Elements;

3. Installations for the furnishing of utility services to more than one Unit or to the Common Elements, specifically excluding however, any utility main lines, force mains or collection lines and meters owned and maintained by the utility company servicing the Condominium Property;
4. The property and installations in connection therewith required for the furnishing of services to more than one Unit or to the Common Elements;
5. The riparian and/or littoral rights, appertaining to the Land, if any;
6. Fixtures owned or held for the common use, benefit and enjoyment of all Unit Owners;
7. Walkways, stairways, covered entrances and verandas located within the Condominium Property; and
8. Automobile parking areas, driveways and paved areas located within the Condominium Property.

C. Limited Common Elements. The term "Limited Common Elements" as used herein shall mean and comprise the "Common Areas" which are reserved herein, or assigned or granted separately herefrom for the use of a certain Unit or Units to the exclusion of other Units consisting of the following:

1. to each unit, the porch (screened or unscreened), patio, terrace or balcony area and other fixtures and equipment, if any, attached, affixed or contiguous to the exterior of and serving only that Unit.

## VI. APPURTENANCES TO UNITS.

There shall be appurtenant, and pass with title to each Unit, the rights, shares and interests provided by the Condominium Act which shall be deemed to include, without limitation, the following:

A. An undivided share in the Common Elements and in the "Common Surplus" (as that term is elsewhere herein defined). The undivided share in the Common Elements and the Common Surplus of the Condominium appurtenant to each Unit is that proportion of the total set forth, as a percentage, in the schedule which is annexed hereto and made a part hereof as Exhibit "B".

B. The right to use exclusively or in common with certain other Units where so specified, those portions of the Common Elements designated and/or reserved herein and/or granted elsewhere to a certain Unit or Units as Limited Common Elements.

C. An exclusive easement for the use of the air space occupied by the Unit as it exists at any particular time (as shown on Exhibit "D" hereto) and as it may lawfully be altered or reconstructed from time to time, which easement shall be terminated automatically in any air space which is permanently vacated from time to time.

D. Non-exclusive easements to be used and enjoyed in common with the owners of all Units in the Condominium, their guests and invitees, for use of the Common Elements, including, without limitation, easements for:

1. the furnishing and maintenance of utility services to all parts of the Condominium Property over, across, in and through the Land, buildings and other improvements, as the fixtures and equipment therefor now exist and/or may be modified or relocated; and

2. vehicular and pedestrian access over, across, upon, in and through the drives, entries, gates, walks, grounds and other portions, if any, of the Common Elements as are intended and/or provided for pedestrian and vehicular traffic through the Condominium and for access to public ways and the improvements, fixtures and equipment thereon.

E. An exclusive easement for the unintentional and non-negligent encroachment by any Unit upon any other Unit or Common Element, or vice versa, for any reason not caused by or resulting from the willful or negligent act of Developer or any Unit Owner(s) including, without limitation, encroachments caused by or resulting from the original construction of improvements, which exclusive easement shall exist at all times during the continuance of such encroachment, as an easement appurtenant to the encroaching Unit or other improvement, to the extent of such encroachment.

F. The right to membership in the Association with full voting rights appertaining thereto (as defined in Paragraph VIII) upon the terms and conditions set forth elsewhere herein.

G. Unit Owners and their guests, invitees and domestic help, and all delivery, pickup and fire protection services, police and other authorities of the law, United States mail carriers, representatives of utilities authorized by Developer to serve the Condominium, holders of mortgage liens on the Condominium or any Unit and such other persons as Developer may from time to time designate shall have the non-exclusive and perpetual right of ingress and egress over and across the real property located within the Condominium intended for vehicular and pedestrian use (hereinafter referred to as "roadways") subject however, to the right of Developer to install, erect, construct and maintain utility lines and facilities in certain portions of the roadways and to erect security gates or other devices to limit access over certain portions of the roadways. Provided, however, notwithstanding the foregoing, Developer reserves and shall have the unrestricted and absolute right to deny ingress over the roadways to any person who, in the opinion of the Association or Developer, may create or participate in a disturbance or nuisance on any part of the Condominium or who, in the opinion of the Association or Developer, may create or participate in a disturbance or nuisance on the Condominium.

Developer and the Association shall have the right, but not the obligation, from time to time to control and regulate all types of traffic on the roadways, including the right to prohibit use of the roadways by traffic or vehicles (including, without limitation, motorcycles, go-carts and skateboards) which in the sole opinion of the Association or Developer would or might result in damage to the roadways or pavement or other improvements thereon, or create a nuisance for the residents, and the right, but not the obligation, to control and prohibit parking on all or any part of the roadways. Developer and the Association shall have the right to establish security procedures for the protection of the property and residents to which access is provided over the roadways, including the right to restrict the rights of the general public to access over the roadways and to require compliance with security procedures by guests and invitees of the Unit Owners.

**VII. COMMON EXPENSES AND COMMON SURPLUS.**

As set forth in Article VIII of this Declaration, the Association will administer the operation and affairs of the Condominium.

The term "Common Expenses" as used herein shall mean all expenses for which the Unit Owners in the Condominium (except the Association) shall be liable to the Association. The term "Common Surplus" as used herein shall mean the excess of all receipts of the Association collected on behalf of the Condominium including, without limitation, assessments, rents, profits and revenues on account of the Common Elements of the Condominium, over the amount of the Common Expenses of the Condominium. All Unit Owners (except the Association) in the Condominium shall share the Common Expenses and shall own the Common Surplus in the proportions or percentages set forth in the schedule annexed hereto and made a part hereof as Exhibit "B".

**VIII. THE ASSOCIATION.**

A. Operation of the Condominium. The entity responsible for the operation of the Condominium shall be CITIHOMES AT SAN MARCO CONDOMINIUM ASSOCIATION, INC. a Florida corporation not-for-profit ("Association") of which a copy of the Articles of Incorporation ("Articles") and Bylaws ("Bylaws") are annexed hereto and made a part hereof as Exhibits "E" and "F", respectively. Subject to the rights reserved to Developer herein and in the Condominium Act to administer and manage the Condominium initially, the Association shall administer and manage the Condominium provided, that the Association may delegate its maintenance, management and operational duties and obligations by contract to the extent permitted by the Condominium Act.

B. Power to Grant Easements. Developer hereby grants to the Association the power to grant easements over the Common Elements without the necessity of joinder of all Unit Owners. The Association's power to grant such easements shall be governed and exercised in accordance with the provisions of the Articles and Bylaws and shall not be exercised in a manner that materially and adversely affects the property rights of any Unit Owner.



IX. BYLAWS OF ASSOCIATION.

A copy of the Bylaws of the Association is annexed hereto and made a part hereof as Exhibit "F".

X. VOTING RIGHTS OF UNIT OWNERS.

The Unit Owner(s) shall become a member or members of the Association automatically upon and simultaneously with delivery of a deed of conveyance of fee title thereto from Developer or, in a conveyance by a grantee or a remote grantee of Developer, a deed which otherwise complies with the terms and conditions of this Declaration, the Articles of Incorporation and Bylaws of the Association. There shall be appurtenant and pass with title to each Unit one vote as a member of the Association ("Voting Interest") which may be exercised by the Unit Owner(s), or the duly constituted proxy of the Unit Owner(s) at all meetings of members and in connection with all matters upon which members of the Association are entitled to vote. The qualification of members of and manner of admission to membership in the Association, the termination of such membership and voting by members shall be as provided for in the Articles of Incorporation and Bylaws of the Association.

XI. AMENDMENT OF DECLARATION.

Except for amendments which Developer is authorized and/or obligated elsewhere herein to make and except as may be elsewhere herein or in the Condominium Act otherwise specifically provided, this Declaration may be amended only in the following manner:

A. Notice. Notice of the subject matter of any proposed amendment to this Declaration shall be included in the notice of any meeting at which such proposed amendment is to be considered.

B. Proposal. Amendments to this Declaration may be proposed by the Board by resolution adopted by a majority vote of the Directors present at any regular or special meeting of the Board at which a quorum is present or, in the alternative, by a written instrument signed by a majority of the Board, or by the Owners of a majority of the Voting Interests, whether by vote of such Unit Owners as members of the Association at a special or regular meeting of the members or by written instrument signed by them.

C. Adoption. Any amendment to this Declaration so proposed by the Board or members of the Association shall be transmitted to the President of the Association or, in the absence of the President, to a Vice President or other acting chief executive officer, who shall thereupon call a special meeting of the Unit Owners to consider and vote upon such proposed amendment; provided, that a proposed amendment may be considered and voted upon at an annual meeting of the members of the Association if the next such meeting is to be held within the time hereafter limited and if notice of the proposed amendment shall be included in the notice of such meeting. The special or



annual meeting, as the case may be, of the members shall be held no sooner than thirty (30) days nor later than sixty (60) days from the date of receipt by the Association of the proposed amendment. Notice of the meeting shall be in the form and shall be delivered and the meeting shall be called and held as provided for in the Bylaws of the Association; provided, that any member may, in writing signed by such member, waive notice of any such meeting in the manner provided for in the Bylaws of the Association and such waiver, when delivered to the Secretary of the Association for filing in its records, whether before, during or after such meeting shall be construed to be the equivalent of giving notice to such member. The proposed amendment may be adopted, and shall become effective, by and upon the affirmative vote at such meeting of Unit Owners owning not less than sixty-six and two-thirds percent (66 2/3%) of the Voting Interests; provided, that any amendment so proposed may be adopted, without a formal meeting of the members, by an instrument executed and acknowledged with the formalities of a deed by members owning not less than sixty-six and two-thirds percent (66 2/3%) of all Voting Interests. Notwithstanding the foregoing provisions for adoption of amendments to this Declaration or any other provisions for amendment in the Condominium Act, no amendment shall:

1. materially change the configuration or size of any Unit, or materially modify any appurtenance to a Unit, unless the record owner thereof and all record owners of liens thereon shall join in the execution and acknowledgment of the amendment;
2. discriminate against any Unit Owner or against any Unit or building or class of buildings comprising part of the Condominium Property, unless the record owners of all affected Units shall join in the execution and acknowledgment of the amendment;
3. change the share of Common Elements appurtenant to any Unit or Units or the share of any Unit Owner in the Common Surplus, or increase the share of any Unit Owner(s) in the Common Expenses, unless the record owners of all Units and the record owners of all liens thereon shall join in the execution and acknowledgment of such amendment; and
4. materially and adversely affect the lien or priority of any previously recorded mortgage to an Institutional Lender, or materially and adversely affect the rights and remedies of Institutional Lenders holding mortgages on five or more Units.

D. Form of Proposed Amendment. No provision of the Declaration shall be revised or amended by reference to its title or number only. Proposals to amend existing provisions of the Declaration shall contain the full text of the provision to be amended; new words shall be inserted in the text underlined; and words to be deleted shall be lined through with hyphens. However, if the proposed change is so extensive that this procedure would hinder, rather than assist, the understanding of the proposed amendment, it is not necessary to use underlining and hyphens as indicators of words added or deleted, but, instead, a notation must be inserted immediately preceding the proposed amendment in substantially the following language: "Substantial rewording of declaration. See provision.... for present text". Nonmaterial errors or omissions in the amendment process shall not invalidate an otherwise properly promulgated amendment.

E. Effective Date and Recording Evidence of Amendment. As to members of the Association and persons having actual knowledge of the adoption of any amendment to this Declaration, such amendment shall be effective as of the date of adoption or otherwise as may be specified in the resolution or instrument creating the amendment. As to nonmembers of the Association without actual knowledge of an amendment to this Declaration, the same shall be effective at the time the affected person acquires actual knowledge thereof or at the time of filing the amendment in the public records of Duval County, Florida, whichever occurs first. The President of the Association or, in the absence of the President, a Vice President or other acting chief executive officer of the Association, shall cause to be filed in the public records of Duval County, Florida, the original amendment to the Declaration, which shall include the recording data identifying this Declaration and which shall be executed in the form required for the execution of a deed. A true and correct copy of each such amendment shall be delivered forthwith, after adoption thereof, to the record owners of all Units by the President, Vice President or other acting chief executive officer of the Association, but delivery of such copies shall not be a condition precedent to the effectiveness of any such amendment.

F. Amendment to Correct Omission or Error in Condominium Documents. Notwithstanding any provision to the contrary set forth in this Article XI or elsewhere, in and of this Declaration, the Articles of Incorporation or Bylaws of the Association, the affirmative vote of the owners of not less than fifty-one percent (51%) of the Units in the Condominium shall be sufficient to adopt an amendment to this Declaration for the purpose of correcting a defect, error or omission in or of this Declaration not materially and adversely affecting the rights of Unit Owners, lienors or mortgagees.

G. Amendment by Developer. Notwithstanding any provision to the contrary set forth in this Article XI or elsewhere in this Declaration or in the Articles of Incorporation or Bylaws of the Association, Developer may, without the consent or joinder of any other party, amend this Declaration (i) to add any surveyor's certificate(s) as described in Article IV; (ii) to amend Exhibit "D" hereof to reflect the floor plans selected by the initial purchasers of the Units pursuant to Article IV; and (iii) to amend any provision of this Declaration in a manner that will not materially and adversely affect the property rights of any Unit Owner other than Developer. Developer's right to amend this Declaration as provided in subsection (ii) of this paragraph G shall cease and be terminated at such time as Developer no longer owns any Unit in the Condominium.

H. Amendments Relating to Surface Water or Stormwater Management System. Notwithstanding any provision to the contrary set forth in this Article XI or elsewhere in this Declaration or in the Articles of Incorporation or Bylaws of the Association, any amendment to this Declaration which alters the Surface Water or Stormwater Management System, as such term is hereafter defined, beyond maintenance in its original condition, or which in any way affects the obligation of the Association to maintain the Surface Water or Stormwater Management System, must have the prior written approval of the St. Johns River Water Management District.

**XII. MAINTENANCE, REPAIRS AND REPLACEMENTS.**

Responsibility for maintenance, repairs and replacements of the Condominium Property and property of Unit Owners located or situated within the Condominium shall be as follows:

A. Units. Each Unit and the fixtures, equipment and appliances comprising a part thereof, located therein or exclusively serving the same shall be maintained, kept in good repair and replaced by and at the expense of the Unit Owner(s) thereof. All maintenance, repairs and/or replacements for which Unit Owners are responsible and obligated to perform, which, if not performed or omitted, would affect other Units or Common Elements, shall be performed promptly as the need arises. Notwithstanding the obligation of Unit Owners for maintenance, repair and replacement of and in Units, the proceeds of all insurance awards or payments under insurance carried by the Association for loss or damage to or within Units shall be applied against repairs and replacements to the extent that such award or payments exceed the deductible provisions of such insurance.

B. Common Elements. The Association shall be responsible for and shall assess against and collect from the Unit Owners, the costs of maintaining, repairing, replacing and keeping in clean and orderly condition all of the Common Elements. The Association shall, at the expense of the Unit Owners, repair any and all incidental damage to Units resulting from maintenance, repairs and/or replacements of or to the Common Elements. The Association's responsibility with respect to the Common Elements shall include, without limitation, the obligation to maintain, operate and repair the Surface Water or Stormwater Management System, as such term as hereafter defined, in accordance with all permit conditions, statutes, rules and regulations enforceable by any governmental authority having jurisdiction including, without limitation, the St. Johns River Water Management District, the Florida Department of Environmental Regulation and the United States Army Corp of Engineers. For purposes of this Declaration, the term Surface Water or Stormwater Management System shall mean and refer to a system which is designed and constructed or implemented to control discharges which are necessitated by rainfall events, incorporating methods to collect, convey, store, absorb, inhibit, treat, use or reuse, water to prevent or reduce flooding, overdrainage, environmental degradation and water pollution or otherwise affect the quantity and quality of discharges from the system, as permitted pursuant to Chapters 40C-4, 40C-40 or 40C-42, Florida Administrative Code. Maintenance of the Surface Water or Stormwater Management System shall mean the exercise of practices which allow the systems to provide drainage, water storage, conveyance or other stormwater management capabilities as permitted by the St. Johns River Water Management District. Any repair or reconstruction of the Surface Water or Stormwater Management System shall be as permitted, or if modified, as approved by the St. Johns River Water Management District. The St. Johns River Water Management District shall have the right to enforce, by a proceeding at law or in equity, the provisions contained in this Declaration which relate to maintenance, operation and repair of the Surface Water or Stormwater Management System.

C. Limited Common Elements. The responsibility for and the cost of keeping clean and in orderly condition those Limited Common Elements which are assigned or granted to, and exclusively serve, a certain Unit or Units to the exclusion of other Units, shall be borne by the owner(s) of the Unit(s) to which the same are appurtenant. The Association shall be responsible for otherwise maintaining and repairing and replacing all Limited Common Elements and shall assess against and collect from all of the Unit Owners the cost of such repair and replacement; however, the owner(s) of the Unit(s) to which a screened porch, deck, or balcony is appurtenant shall be responsible for the cost of repairing and replacing all screening and glass located therein, and such Unit Owners shall be responsible for repairing and replacing any wooden decking and fixtures such as hot tubs or other equipment located upon the porch, deck or balcony area appurtenant to such Unit.

### XIII. INSURANCE.

Insurance shall be carried and kept in force at all times in accordance with the following provisions:

A. Duty and Authority to Obtain. The Association shall obtain and keep in force at all times the insurance coverage which it is required hereby to carry and may obtain and keep in force all of such other or additional insurance coverage as it is authorized hereby to carry. All insurance obtained by the Association shall be purchased for the benefit of the Association and the Unit Owners and their mortgagees. A certificate evidencing a mortgagee endorsement shall be issued to the mortgagee of each Unit upon the request of such mortgagee. The Unit Owner(s) of each Unit may, at the expense of the Unit Owner(s), obtain insurance coverage against damage to and loss of the contents of the Unit, personal liability for injury to and death of persons and damage to and loss of personal property of others, and against additional living expenses, provided, that all such insurance purchased by Unit Owners may be obtained from the insurer from which the Association purchases coverage against the same risk, liability or peril, if the Association has such coverage; and, provided, that each policy of such insurance purchased by a Unit Owner shall, where such provision is available, provide that the insurer waives its right of subrogation as to any claim or claims against other Unit Owners, the Association, and their respective employees, agents, guests and invitees. In any event, any insurance policy purchased by an individual Unit Owner shall provide that coverage afforded by such policy is excess over the amount recoverable under any other policy covering the same property without rights of subrogation against the Association.

B. Required Coverage. The Association shall purchase and carry casualty insurance covering all of the buildings and other improvements of the Condominium including, without limitation, Units and Common Elements, in an amount equal to the maximum insurance replacement value thereof, exclusive of excavation and foundation costs, as determined annually by the Board; such insurance to include or afford protection against:

1. loss or damage by fire or other hazards covered by the standard extended coverage or other perils endorsements;



2. such other risks of a similar or dissimilar nature as are or shall be customarily covered with respect to buildings and other improvements similar, in construction, location and use, to the buildings and other improvements of the Condominium including, without limitation, vandalism, malicious mischief, windstorm, water damage and war risk insurance, if available;

3. public liability insurance, in such amounts, with such coverage and in such forms as shall be required by the Board to protect the Association and the Unit Owners of all Units, including, without limitation, hired automobile, non-owned automobile, off premises employee coverage, water damage and legal liability, with cross-liability endorsements to cover liability of all Unit Owners as a group to each Unit Owner and waiver of rights of subrogation;

4. workmen's compensation insurance to meet the requirements of law;

5. loss or damage by flood, to the extent, if any, required or necessitated by law, including, without limitation, the Flood Disaster Protection Act of 1973, or any similar law or regulation; and

6. fidelity bonds as may be required under the Condominium Act.

C. Optional Coverage. The Association may purchase and carry such other insurance coverage, other than title insurance, as the Board, in its sole discretion, may determine from time to time to be in the best interests of the Association and Unit Owners, or as an Institutional Lender may reasonably require while it holds a mortgage encumbering any Unit.

D. Premiums. Premiums for all insurance obtained and purchased by the Association shall be paid by the Association. The cost of insurance premiums, and other incidental expenses incurred by the Association in administering and carrying out the provisions of this Article, shall be assessed against and collected from Unit Owners as Common Expenses.

E. Assured. All policies of insurance obtained and purchased by the Association shall be for the benefit of the Association, its members and their mortgagees, as their interests may appear, shall provide that all proceeds covering casualty losses shall be paid to the Condominium Association or "Insurance Trustee" as hereinafter provided or to its successor as set forth herein, and the proceeds from insurance against any casualty loss shall be held for the use of the Association, the Unit Owners and their respective mortgagees, as their interests may appear, to be applied or distributed in the manner herein provided. The Association is hereby constituted and appointed agent for all Unit Owners, with authority to negotiate and settle the value and extent of any and all losses covered under any policy of casualty insurance, and the Association is granted full right and authority to execute, in favor of any insurer, a release of liability arising out of any occurrence covered by any policy or policies of casualty insurance and resulting in loss of or damage to insured property.

F. Insurer. All persons beneficially interested in the insurance coverage obtained, purchased and maintained by the Association shall be bound by the Association's selection of its insurer(s) and the amount of insurance coverage carried and kept in force by the Association.

G. Insurance Trustee. The Association shall have the right to designate the Insurance Trustee and all persons beneficially interested in such insurance coverage shall be bound by the Association's selection of the Insurance Trustee.

1. ***Qualifications, Rights and Duties.*** The Insurance Trustee shall be a bank with trust powers, doing business in the State of Florida, or if no such Insurance Trustee is designated, shall be the Board of Directors of the Association. The Insurance Trustee shall not be liable for the payment of premiums, the renewal of any policy or policies of casualty insurance, the sufficiency of coverage, the form or content of policies nor for the failure to collect any insurance proceeds. The sole duty of the Insurance Trustee shall be to receive such proceeds of casualty insurance as are paid and to hold the same in trust for the purposes herein stated, and for the benefit of the Association, Unit Owners and their respective mortgagees, to be disbursed as herein provided. The Association shall pay a reasonable fee to the Insurance Trustee for services rendered hereunder and shall pay such costs and expenses as the Insurance Trustee may incur in the performance of its duties hereunder; such fees and costs to be assessed against and collected from Unit Owners as a Common Expense. The Insurance Trustee shall be liable only for its willful misconduct, bad faith or gross negligence, and then only for such money as may come into the possession of the Insurance Trustee. If and when the Insurance Trustee is required to distribute insurance proceeds to Unit Owners and their mortgagees, as their respective interests may appear, the Insurance Trustee may rely upon a certificate of the President and Secretary of the Association, executed under oath and provided to the Insurance Trustee upon request to the Association; such certificate to certify the name or names of the Unit Owners, the mortgagee(s) thereof, and the respective percentages of any distribution which is to be made to the Unit Owner(s) and mortgagee(s), as their respective interests may appear. If and when insurance proceeds are paid to the Insurance Trustee for any casualty loss, the holder(s) of any mortgage or mortgages encumbering a Unit shall not have the right to determine or participate in the determination of repair or replacement of any loss or damage, and shall not have the right to elect to apply insurance proceeds to the reduction of indebtedness secured by such mortgage(s), unless the insurance proceeds represent a distribution to the Unit Owner(s) and the mortgagee(s) thereof, after such insurance proceeds have been first applied to repair, replacement or reconstruction of any loss or damage, or unless such casualty insurance proceeds are authorized to be distributed to the Unit Owner(s), and the mortgagee(s) thereof by reason of loss of or damage to personal property constituting a part of the Common Elements and as to which a determination is made not to repair, replace or restore such personal property.

H. Application of Insurance Proceeds. The proceeds of casualty insurance paid to the Insurance Trustee by an insurer for loss or damage to real and/or personal property upon which the Association carries insurance, shall be applied and paid as follows:

1. ***Common Elements Only.*** The proceeds paid to the Insurance Trustee for loss of or damage to real property or improvements constituting Common Elements only shall be applied to the repair, replacement or reconstruction of such loss or damage. If such insurance proceeds exceed the cost of the repair, replacement or reconstruction of such Common Elements, the excess shall be paid by the Insurance Trustee to the Unit Owners, and their respective mortgagees, as their interests may appear, in shares or proportions equal to the undivided interest appurtenant to each Unit in the Common Elements. If the insurance proceeds shall be insufficient to pay the cost of the repair, replacement or reconstruction of such Common Elements, the Association shall deposit with the Insurance Trustee, from any Association reserve fund which may have been established, the difference between the total cost of repairing, replacing or reconstructing such loss or damage to the Common Elements and the amount of the insurance proceeds. If no such Association reserve fund has been established, or if any such Association reserve fund has been established and is insufficient to pay to the Insurance Trustee such difference, the Association shall assess the amount of the difference against, and collect it from, all Unit Owners, as a Common Expense.

2. ***Units and Common Elements.*** The proceeds paid to the Insurance Trustee for loss of or damage to a building, constituting Common Elements and one or more Units thereof only, shall be first applied to the repair, replacement or reconstruction of Common Elements, then to the repair, replacement or reconstruction of any Unit or Units in such building which have been destroyed or damaged. If such insurance proceeds exceed the cost of the repair, replacement or reconstruction of such Common Elements and Units, the excess shall be paid by the Insurance Trustee to the owners of the damaged or destroyed Units and their respective mortgagees, as their interests may appear, in shares or proportions equal to the undivided interest appurtenant to each such Unit in the Common Elements. If the insurance proceeds shall be sufficient to pay for the repair, replacement or reconstruction of the Common Elements but shall be insufficient to pay the cost of the repair, replacement or reconstruction of the damaged or destroyed Unit or Units in such building, each Unit Owner shall be responsible for the portion of the deficiency attributable to his Unit and shall deposit such sum with the Insurance Trustee to be applied by the Insurance Trustee toward the total cost of repairing, replacing or reconstructing all of such damaged or destroyed Common Elements and Units. If the insurance proceeds shall be insufficient to pay the cost of the repairs, replacements, or reconstruction of the Common Elements (to which the Insurance Trustee is required first to apply such proceeds before applying any part thereof to the repair, replacement or reconstruction of Units), the difference between the total cost of repairing, replacing or reconstructing the Common Elements and the amount of the insurance proceeds shall be assessed by the Association against, and collected from, all Unit Owners as a common expense and in such event, the cost of repairing, replacing or reconstructing the Unit or Units destroyed or damaged shall be the responsibility of the Owners of such damaged or destroyed Units, who shall each deposit with the Insurance Trustee the amount necessary to repair, replace or reconstruct their respective Units.

I. **Deposits to Insurance Trustee After Damage.** Within sixty (60) days after a loss of or damage to Condominium Property covered by casualty insurance, the Association shall obtain estimates of the cost of repairing, replacing or restoring the same, including the cost of professional fees and any construction bond which the Board may require. If, from such estimates, it shall appear

that the insurance proceeds payable for such loss or damage will be insufficient to pay the total costs thereof, whether it is to be paid by one or more Unit Owners, the deficit shall be deposited with the Insurance Trustee not later than thirty (30) days from the day on which the Insurance Trustee receives the insurance proceeds.

**XIV. RECONSTRUCTION OR REPAIR AFTER CASUALTY.**

Whether, and the manner in which, any or all of the Condominium Property which shall be damaged or destroyed by casualty shall be repaired, reconstructed or replaced shall be determined as follows:

A. Residential Buildings. If any residential building shall be damaged or destroyed, repair or reconstruction thereof, or termination of the Condominium, shall be in accordance with the following:

1. ***Total Destruction of all Residential Buildings.*** If all residential buildings within the Condominium are totally destroyed or are so damaged that no Unit therein is habitable, the buildings and none of the improvements comprising Common Elements shall be reconstructed, and the Condominium shall be terminated unless the owners of Units to which seventy-five (75%) of the Common Elements are appurtenant and mortgagees holding first mortgages on not less than fifty-one percent (51%) of the Units agree in writing, within sixty (60) days after the date of such destruction, to reconstruct the same and/or unless any policy or policies of casualty insurance covering the same shall require reconstruction thereof as a condition precedent to the payment of proceeds thereunder and in either case as long as the then applicable zoning and other regulatory laws and ordinances shall allow the same to be reconstructed.

2. ***Partial Destruction of the Residential Buildings.*** If one or more, but less than all of the Units in the buildings remain habitable, the damaged or destroyed Common Elements and/or Units shall be repaired or reconstructed so that the buildings and/or Units shall be restored to substantially the same condition as existed prior to such damage or destruction, unless within sixty (60) days after the casualty it is determined by agreement of the Unit Owners and mortgagees in the manner provided in Article XI hereof, that the Condominium shall be terminated.

B. Common Elements. Damaged or destroyed improvements constituting part of the Common Elements shall be repaired, reconstructed and/or replaced unless in the event of total destruction of the Units, or by agreement after partial destruction, the Condominium shall be terminated.

C. Certificate. The Insurance Trustee may rely upon a certificate executed by the President and Secretary of the Association to determine whether or not damaged or destroyed Condominium Property shall be repaired or reconstructed.



D. Plans and Specifications. Repair or reconstruction of the Condominium Property shall be substantially in accordance with the plans and specifications pursuant to which the same were originally constructed, provided that the Board may authorize reasonable variations from the original plans and specifications as may appear to them to be necessary or desirable.

E. Responsibility. If the damage or destruction shall be limited only to one or more Units for which the responsibility of maintenance, repair and replacement is that of the affected Unit Owners, then such Unit Owners shall be responsible for carrying out the repair or reconstruction thereof. In all other instances of damage or destruction, the Association shall be responsible for carrying out the repair and reconstruction thereof.

F. Construction Funds. All funds for the payment of repair and reconstruction costs, consisting of insurance proceeds and/or funds collected by the Association from Unit Owners shall be disbursed toward payment of such costs in the following manner:

1. **Association.** If the total funds assessed against and collected from Unit Owners by the Association for payment of repair and reconstruction costs is more than Five Thousand and no/100 Dollars (\$5,000.00) then all such sums shall be deposited by the Association with and disbursed by the Insurance Trustee. In all other cases the Association shall hold such sums so assessed and collected and shall disburse the same in payment of the costs of reconstruction and repair.

2. **Insurance Trustee.** The proceeds of insurance collected on account of a casualty and the sums assessed against and collected from Unit Owners by the Association and deposited with the Insurance Trustee shall constitute a construction fund which shall be disbursed in payment of the costs of repair and reconstruction in the following manner:

(a) **Unit Owner.** The portion of insurance proceeds representing damage for which the responsibility of repair and reconstruction is upon one or more, but less than all Unit Owners, shall be paid by the Insurance Trustee to the affected Unit Owners and, if any of such Units are mortgaged, to the affected Unit Owners and their mortgagees jointly, or in such other method as the effective insurance policy shall require.

(b) **Association--Lesser Damage.** If the amount of the estimated costs of reconstruction and repair which is the responsibility of the Association is less than Five Thousand and no/100 Dollars (\$5,000.00) then the construction fund shall be disbursed in payment of such costs upon the order of the Association; provided, however, that upon request to the Insurance Trustee by a mortgagee which is a beneficiary of an insurance policy the proceeds of which are included in the construction fund, such fund shall be disbursed in the manner hereafter provided for the reconstruction and repair of major damage.

(c) **Association--Major Damage.** If the amount of the estimated costs of reconstruction and repair which is the responsibility of the Association is more than Five Thousand and no/100 Dollars (\$5,000.00) then the construction fund shall be disbursed in payment of such costs in the manner required by the Board and upon approval of an architect registered to practice in Florida and employed by the Association to supervise the work.

(d) **Surplus.** It shall be presumed that the first monies disbursed in payment of costs of reconstruction and repair shall be from insurance proceeds. If there is a balance in the construction fund after payment of all costs of the reconstruction and repair for which the fund is established, such balance shall be distributed to the beneficial owners of the fund in the manner elsewhere herein stated; except, however, that the part of a distribution to a beneficial owner which is not in excess of assessments paid by such owner into the construction fund shall not be made payable to any mortgagee.

(e) **Certificate.** Notwithstanding the provisions herein, the Insurance Trustee shall not be required to determine whether or not sums paid by Unit Owners upon assessments shall be deposited by the Association with the Insurance Trustee, nor to determine whether the disbursements from the construction fund are to be upon the order of the Association or upon approval of an architect or otherwise, nor whether a disbursement is to be made from the construction fund nor to determine the payee nor the amount to be paid, nor to determine whether surplus funds to be distributed are less than the assessments paid by Unit Owners. Instead, the Insurance Trustee may rely upon a certificate of the Association made by its President and Secretary as to any or all of such matters and stating that the sums to be paid are due and properly payable and stating the name of the payee and the amount to be paid; provided that when a mortgagee is herein required to be named as payee the Insurance Trustee shall also name the mortgagee as payee; and further provided that when the Association, or a mortgagee which is the beneficiary of an insurance policy the proceeds of which are included in the construction fund, so requires, the approval of an architect named by the Association shall be first obtained by the Association.

#### XV. USE RESTRICTIONS.

Use of the Condominium Property shall be in accordance with and subject to the following provisions so long as the Condominium exists:

A. Units. Each of the Units shall be occupied only by a single family, its servants and guests or lessees as a residence and for no other purposes.

B. Common Elements and Limited Common Elements. The Common Elements and Limited Common Elements shall be used only for the purposes for which they are intended in the furnishing of services and facilities for the enjoyment of such improvements.

C. Nuisances. No nuisances shall be allowed upon the Condominium Property, nor any use or practice which is the source of annoyance to residents or which interferes with the peaceful possession and proper use of the Condominium Property by residents. All parts of the Condominium Property shall be kept in a clean and sanitary condition, and no rubbish, refuse or garbage shall be allowed to accumulate, nor shall any fire hazard be allowed to exist. No use shall be made of any Unit or of the Common Elements which will increase the rate of insurance upon the Condominium Property.

D. Lawful Use. No immoral, improper, offensive or unlawful use shall be made of the Condominium Property or any part thereof; and all valid laws, zoning ordinances and regulations of all governmental bodies having jurisdiction thereof shall be observed. The responsibility of meeting the requirements of governmental bodies pertaining to maintenance, replacement, modification or repair of the Condominium Property shall be the same as is elsewhere herein specified.

E. Regulations. Reasonable regulations concerning the use of the Condominium Property may be made and amended from time to time by the Board. Such regulations may include, without limitation, limitations on the number, size and species of pets which may be kept within the Condominium Property. No such regulation shall contravene any portion of this Declaration or of the Association's Articles of Incorporation or Bylaws. Copies of such regulations and amendments thereto shall be furnished by the Association to all Unit Owners and residents of the Condominium upon request.

F. Proviso. Until Developer has sold all of the Units, neither the Unit Owners nor the Association shall interfere with the sale of the Units. Developer may make such use of the unsold Units and Common Elements (including, without limitation, the clubhouse) as may facilitate such sales, including, but not limited to, maintenance of sales offices and model units, the display of signs and use of the Common Elements in the promoting of sales of Units in the Condominium.

G. Rights of Developer. Developer, for itself, its successors, assigns, nominees, designees and grantees, hereby reserves a perpetual, alienable, releasable and non-exclusive easement, privilege and right of ingress and egress over and across all paved roadways and drives located within the Condominium Property. Developer shall have the unrestricted and sole right and power of assigning in whole or in part, alienating and releasing the privileges, easement and rights referred to in this paragraph. Such easement is and shall remain a private easement and the sole and exclusive property of Developer, its successors, assigns, nominees, designees and grantees; provided, however, such easement rights shall not be used so as to interfere with the installation and location of completed vertical improvements upon the Condominium Property.

## XVI. COMPLIANCE AND DEFAULT.

Each Unit Owner shall be governed by and shall comply with the terms of the Declaration of Condominium, the Articles of Incorporation and Bylaws of the Association, and any and all

regulations adopted pursuant thereto, as they may be amended from time to time. Failure of the Unit Owner to comply therewith shall entitle the Association or other Unit Owners to the following relief in addition to the remedies provided by the Condominium Act:

A. Negligence. Each Unit Owner shall be liable for the expense of any maintenance, repair or replacement rendered necessary by his act, neglect or carelessness or by that of any member of his family or his or their guests, employees, agents, lessees or other invitees, but only to the extent that such expense is not met by the proceeds of insurance carried by the Association.

B. Costs and Attorneys' Fees. In any proceeding arising because of an alleged failure of a Unit Owner to comply with the terms of the Declaration, the Articles of Incorporation and Bylaws of the Association and any and all regulations adopted pursuant thereto, as they may be amended from time to time, the prevailing party shall be entitled to recover the costs of the proceeding and such reasonable attorneys' fees as may be awarded by the court.

C. Fines, etc. The Association shall be authorized to levy reasonable fines against Unit Owners for violations of the terms and conditions of this Declaration, the Articles of Incorporation and Bylaws of the Association, and any and all regulations adopted pursuant thereto. No fine may exceed One Hundred and no/100 Dollars (\$100.00) for any single violation, except that a fine may be levied on the basis of each day of a continuing violation. In such event, the fine shall not exceed One Thousand and no/100 Dollars (\$1,000.00) in the aggregate. No fine may be levied except after giving reasonable notice and opportunity for a hearing before a committee comprised of Unit Owners appointed by the Board of Directors to the offending Unit Owner in accordance with procedures to be established by the Board. No fine shall be imposed with respect to any unoccupied Unit.

D. No Waiver of Rights. The failure of the Association or any Unit Owner to enforce any covenant, restriction or other provision of the Condominium Act, this Declaration, the Articles of Incorporation and Bylaws of the Association or the regulations adopted pursuant thereto, shall not constitute a waiver of the right to do so thereafter.

#### **XVII. ASSESSMENTS: LIABILITY, LIEN AND ENFORCEMENT.**

To provide the funds necessary for proper operation and management of the Condominium Property, the Association has been granted the right to make, levy and collect assessments against the Units and Unit Owners. The following provisions shall govern the making, levying and collecting of such assessments and the payment of the costs and expenses of operating and managing the Condominium and Association Property by the Association.

A. Determination of Assessments.

1. Assessments by the Association against each Unit Owner and his Unit shall be the share of the total assessments to be made against all Unit Owners and their Units as is set forth on Exhibit "B" attached hereto.

2. Should the Association become the Unit Owner, the assessment which would otherwise be due and payable to the Association by a Unit Owner, reduced by an amount of income which may be derived from the leasing of such Unit(s) by the Association, shall be apportioned and the assessment therefor levied ratably among all Unit Owners which are not owned by the Association, based upon their proportionate interests in the Common Elements exclusive of the interests therein appurtenant to any Unit or Units owned by the Association.

B. Time for Payment. The assessment levied against the Unit Owner and his Unit shall be payable in quarterly or monthly, or such other installments and at such time as shall from time to time be fixed by the Board as permitted by the Condominium Act.

C. Annual Budget. The Board shall establish annual budgets in advance for each fiscal year which shall estimate all expenses for the forthcoming fiscal year required for the proper operation, management and maintenance of the Condominium, including, when deemed necessary or advisable by the Board, a reasonable allowance for contingencies and reserves and shall estimate all income to be collected during the year. Upon adoption of each annual budget by the Board, copies thereof shall be delivered to each Unit Owner, and the assessment for the year shall be based upon such budget. Failure to deliver a copy of the budget to a Unit Owner shall, however, not affect the liability of the Unit Owner for such assessment. Should the Board at any time and from time to time determine, in the sole discretion of the Board, that the assessments levied are or may prove to be insufficient to pay the costs of operation and management of the Condominium, or in the event of emergencies, the Board shall have the authority to levy such additional assessment or assessments as it shall deem to be necessary. The specific purpose of any special assessment approved by the Board shall be set forth in a written notice of such assessment sent or delivered to each Unit Owner. The funds collected pursuant to a special assessment shall be used only for the specific purpose or purposes set forth in such notice, or returned to the Unit Owners. However, upon completion of such specific purpose or purposes, any excess funds shall be considered Common Surplus. Without limiting the generality of the foregoing, assessments shall be used for the operation, maintenance and repair of the Surface Water or Stormwater Management System including, but not limited to, work within retention areas, drainage structures and drainage easements.

D. Reserve Fund. The Board, in establishing each annual budget for the Condominium, shall include therein a sum to be collected and maintained as a reserve fund for the capital expenditures, deferred maintenance and replacement of the Common Elements and personal property held for the joint use and benefit of all Unit Owners. The amount to be reserved shall be computed by dividing the estimated replacement cost of an item by its estimated remaining useful life. No such reserve shall be included within the annual budget for the Condominium Property if the Unit



Owners, by a majority of votes at a duly called meeting of the Association, elect to provide no fiscal reserves or a lesser amount of fiscal reserves than as provided herein for any fiscal year. If a meeting of the Unit Owners has been called to determine to provide no reserves or reserves less adequate than required, and such result is not attained or a quorum is not attained, the reserves, as included in the Annual Budget, shall go into effect.

E. General Operating Reserve. The Board, when establishing each annual budget, may, when deemed necessary or desirable, include therein a sum to be collected and maintained as a general operating reserve to provide a measure of financial stability during periods of special stress when such sums may be used to meet deficiencies from time to time existing as a result of delinquent payment of assessments by Unit Owners, as a result of emergencies or for other reason placing financial stress upon the Association.

F. Use of Association Funds. All monies collected by the Association shall be treated as the separate property of the Association, and such monies collected from the Unit Owners may be applied by the Association to the payment of any expense of operating and managing the Condominium Property, or to the proper undertaking of all acts and duties imposed upon it by virtue of this Declaration, the Articles, and Bylaws and as the monies for annual assessments are paid to the Association by any Unit Owner, the same may be commingled with monies paid to the Association by the other Unit Owners. The prior sentence notwithstanding, funds received by the Association from other Unit Owners or otherwise attributable to other condominiums which may be administered by the Association, shall not be commingled with funds collected by the Association which are attributable to the Condominium. Although all funds and other assets of the Association, and any increments thereto or profits derived therefrom, or from the leasing or use of Common Elements, including, without limitation, Common Surplus, shall be held for the benefit of the members of the Association, no member of the Association shall have the right to assign, hypothecate, pledge or in any manner transfer his membership interest therein, except as an appurtenance to his Unit.

G. Delinquency or Default. The payment of any assessment or installment thereof due to the Association shall be in default if not paid to the Association on or before the due date thereof. Upon such default, the Association shall be entitled to charge an administrative fee, in addition to interest, in an amount not to exceed Twenty-five and no/100 Dollars (\$25.00) or five percent (5%) of the delinquent installment, for each installment due that is late. Upon default and upon recording a claim of lien Pursuant to this Article XVII, the Association shall have the option of accelerating all remaining installments due from the defaulting Unit Owner for the remainder of the budget year in which the default occurs. When in default, the delinquent assessments (or accelerated installments thereof, if applicable) shall bear interest at the highest rate permitted under applicable law until the same, and all interest due thereon, has been paid in full.

H. Personal Liability of Unit Owner. Each Unit Owner shall be personally liable, jointly and severally, as the case may be, to the Association for the payment of all assessments, regular or special, interest on such delinquent assessments or installments thereof as above provided, and for

all cost of collecting the assessments and interest thereon, including reasonable attorney's fee, whether suit be brought or not, levied or otherwise coming due while such person(s) or entity own(s) a Unit.

I. Liability Not Subject to Waiver. No Unit Owner of a Unit may exempt himself from liability for any assessment levied against the Unit Owner and his Unit by waiver of the use or enjoyment of any of the Common Elements or by abandonment of the Unit, or in any other manner.

J. Lien for Assessment. The Association is hereby granted a lien upon each Unit and its appurtenant undivided interest in Common Elements which lien shall and does secure the monies due for all (1) assessments (or accelerated installments thereof, if the Association elects to accelerate installments under paragraph G above) levied against the Unit Owner(s) and each Unit, (2) interest, if any, which may become due on delinquent assessments owing to the Association, and (3) costs and expenses, including a reasonable attorney's fee, which may be incurred by the Association in enforcing its lien upon the Unit. The lien granted to the Association may be established and foreclosed in the Circuit Court in and for Duval County, Florida, and in any suit for the foreclosure of said lien, upon the approval of such Circuit Court, the Association shall be entitled to rental from the Unit Owner of any Unit from the date on which the payment of any assessment or installment thereof became delinquent and shall be entitled to the appointment of a Receiver for said Unit. The rental required to be paid shall be established by the Circuit Court.

K. Recording and Priority of Lien. The lien of the Association shall be effective from and after recording this Declaration in the public records of Duval County, Florida. However, as to first mortgagees of record, the lien is effective from and after recording a claim of lien. The claim of lien shall state the description of the Unit encumbered thereby, the name of the record owner, the name and address of the Association and the amount and the date when due. The claim of lien shall continue in effect until all sums secured thereby shall have been fully paid, however no claim of lien shall continue for a longer period than one (1) year after the claim of lien has been recorded, unless within that time an action to enforce the lien is commenced in a court of competent jurisdiction. Such claims of lien shall secure unpaid assessments, interest, costs, attorney's fees and interest thereon which are due and which may accrue subsequent to the recording of the claim of lien and prior to entry of a final judgment of foreclosure, all as above provided. Such claims of lien shall be signed and verified by an officer or agent of the Association. Upon full payment of all sums secured by such claim of lien, the same shall be satisfied of record.

L. Effect of Foreclosure or Judicial Sale. A first mortgagee who acquires title to the Unit by foreclosure or deed in lieu of foreclosure is liable for the unpaid assessments that became due prior to the mortgagee's receipt of the certificate of title or deed, as applicable. However, such mortgagee's liability is limited to a period not to exceed six (6) months, but in no event shall such mortgagee's liability exceed one percent (1%) of the original mortgage debt. In no event shall the mortgagee be liable for more than six (6) months of the Unit's unpaid Common Expenses or assessments accrued before the acquisition of title to the Unit by the mortgagee, or one percent (1%) of the original mortgage debt, whichever is less.

M. Effect of Voluntary Transfer. When the Unit Owner proposes to lease, sell or mortgage the Unit, the Association, within fifteen (15) days of written request of the Unit Owner, shall furnish to a proposed purchaser or mortgagee, a statement verifying the status of payment of any assessment or other monies which shall be due and payable to the Association by the owner of such Unit. Such statement shall be executed by any officer of the Association and any lessee, purchaser or mortgagee may rely upon such statement in concluding the proposed lease, purchase or mortgage transaction and the Association shall be bound by such statement.

In the event that a Unit is to be leased, sold or mortgaged at the time when payment of any assessment against the Unit Owner and Unit due to the Association shall be in default (whether or not a claim of lien has been recorded by the Association) then the rent, proceeds of such sale or mortgage proceeds, as the case may be, shall be applied by the lessee, purchaser or mortgagee first to payment of any then delinquent assessment or installment thereof due to the Association before payment of the balance of such rent, proceeds of sale or mortgage to the Unit Owner responsible for payment of such delinquent assessment.

In any voluntary conveyance of a Unit, the grantee shall be jointly and severally liable with the grantor for all unpaid assessments against the grantor made prior to the time of transfer of title, without prejudice to the rights of the grantee to recover from the grantor the amounts paid by the grantee therefor.

Institution of a suit at law to attempt to effect collection of the payment of any delinquent assessment shall not be deemed to be an election by the Association which shall prevent its thereafter seeking enforcement of the collection of any sums remaining owing to it by foreclosure, nor shall proceeding by foreclosure to attempt to effect such collection be deemed to be an election precluding the institution of suit at law to attempt to effect collection of any sum then remaining owing to it.

N. Commencement of Assessments. The date of commencement of the assessments against each Unit as described in this Article shall be established by the Board.

#### **XVIII. REGISTRY OF OWNERS AND MORTGAGEES.**

The Association shall at all times maintain a register of the names of the Unit Owners and their respective mortgagees which shall be based upon information supplied by the Unit Owners. Upon the transfer of title to any Unit, the transferee shall notify the Association in writing of his interest in such Unit together with recording information identifying the instrument by which such transferee acquired his interest in the Unit. The Unit Owner of a Unit encumbered by a mortgage shall notify the Association of the name and address of the mortgagee, the amount of such mortgage, or mortgages, and the recording information identifying the same. The holder of any mortgage encumbering a Unit may notify the Association of any such mortgage(s), and upon receipt of such notice, the Association shall register in its records all pertinent information pertaining to the same.



**XIX. ALTERATIONS OF AND IMPROVEMENTS TO UNITS AND COMMON ELEMENTS.**

Neither a Unit Owner nor the Association shall make any alterations, improvements or additions to Units, Common Elements or Limited Common Elements, except in compliance with the following:

A. Units and Limited Common Elements. Unless the Unit Owner(s) shall first submit plans for such work to the Board and the Board, by resolution unanimously adopted by the affirmative vote of all members thereof, shall approve and consent thereto, no alteration of or improvement or addition to a Unit or to a Limited Common Element to which the Unit Owner(s) has an exclusive right of use shall be made, constructed, erected or installed which shall:

1. remove, in whole or in part, replace, reroute or otherwise affect any column, bearing wall or partition, pipe, duct, wire or conduit or obstruct any easement herein provided for;
2. remove or change the style, pattern, material, texture or outside color of any door, window, screen, fixture, equipment or appliance in or on an exterior Unit or building wall;
3. cover, from the inside or outside, the glass or other transparent and/or translucent material in any exterior door or window with, or apply or affix thereto, any material or substance which shall render the same opaque or change the exterior color thereof, except interior draperies, curtains, shades or shutters which are lined, backed, covered or painted on the side visible from the exterior with a neutral color material;
4. enclose in any fashion or install any flooring other than that which is approved by the Board on a balcony, patio, porch or terrace;
5. affix to or over any exterior door or window, or otherwise install on the exterior of any Unit or building, any storm or hurricane shutter or awning or any protective or decorative panel, paneling, trim, enclosure, fixture or appliance. Notwithstanding anything in this Declaration to the contrary, the Board shall adopt hurricane shutter specifications for each building within the Condominium which shall include color, style and other factors deemed relevant by the Board. All such specifications adopted shall comply with the applicable building code. The Board shall not refuse approval of the installation or replacement of hurricane shutters conforming to the specifications adopted by the Board. The installation, replacement and maintenance of such shutters in accordance with the procedures set forth herein shall not be deemed a material alteration to the Common Elements for purposes of this Declaration; and
6. otherwise change, modify or alter the exterior of any Unit or building so that it thereby differs in appearance from any other Units or buildings of the same type.

B. Common Elements. There shall be no material alterations or substantial improvements or additions to the Common Elements except as hereafter set forth. Upon the affirmative vote of a majority of the members of the Board, the Association shall have the right to make or cause to be made alterations, improvements and/or additions to the Common Elements, except the acquisition of additional real property. The acquisition of additional real property shall be approved by seventy-five percent (75%) of the Voting Interests in the Association. The cost of such alterations, improvements and/or additions shall be assessed against and collected from all Unit Owners as Common Expenses.

In any litigation or other dispute related to or arising out of this Article XIX, the prevailing party shall be entitled to reimbursement of its costs incurred in the litigation or dispute including, without limitation, reasonable attorneys' fees for both trial and appeal.

## XX. TERMINATION.

The Condominium may be terminated in the following manner in addition to the manner provided by the Condominium Act:

A. Destruction. In the event it is determined in the manner elsewhere herein provided that the improvements shall not be reconstructed because of total destruction or major damage, the Condominium plan of ownership will be thereby terminated without agreement.

B. Agreement. The Condominium may be terminated at any time by the approval in writing of all of the Unit Owners in the Condominium, and by all record owners of mortgages upon Units therein owned by Institutional Lenders and other mortgagees approved by the Association. If the proposed termination is submitted to a meeting of the members of the Association (the notice of which meeting gives notice of the proposed termination) and if the approval of the Owners of Units to which not less than seventy-five percent (75%) of the Common Elements are appurtenant and of the record owners of first mortgages encumbering seventy-five percent (75%) of the Units in the Condominium owned by Institutional Lenders are obtained not later than thirty (30) days from the date of such meeting, then the approving Unit Owners shall have an option to buy all of the Units of the other Unit Owners for the period ending on the sixtieth (60th) day from the date of such meeting. Such option shall be upon the following terms:

1. *Exercise of Option*. The option shall be exercised by delivery or mailing by certified mail of an agreement to purchase signed by the record owners of Units who will participate in the purchase to each of the Unit Owners of the Units to be purchased. The agreement shall indicate which Units will be purchased by each participating Owner and shall agree to purchase all of the Units owned by Owners not approving the termination, but the agreement shall effect a separate contract between each seller and his purchaser.

2. **Price.** The sale price for each Unit shall be the fair market value determined by agreement between the seller and purchaser within thirty (30) days from the delivery or mailing of such agreement, and in the absence of agreement as to price, it shall be determined by arbitration in accordance with the then existing rules of the American Arbitration Association, except that the arbitrators shall be two appraisers appointed by the American Arbitration Association who shall base their determination upon an average of their appraisals of the Unit; and a judgment of specific performance of the sale upon the award rendered by the arbitrators may be confirmed in any court of competent jurisdiction. The expense of the arbitration shall be paid by the purchaser.

3. **Payment.** The purchase price shall be paid in full in cash or shall include assumption of any existing mortgage financing plus cash.

4. **Closing.** The sale shall be closed within ten (10) days following the determination of the sale price.

C. **Certificate.** The termination of the Condominium in either of the foregoing manners shall be evidenced by a certificate of the Association executed by its President and Secretary certifying as to facts effecting the termination, which certificate shall become effective upon being recorded in the public records of Duval County, Florida.

D. **Shares of Owners After Termination.** After termination of the Condominium, the Unit Owners shall own the Condominium Property and all assets of the Association as tenants in common in undivided shares, and their respective mortgagees and lienors shall have mortgages and liens upon the respective undivided shares of the Unit Owners. Such undivided shares of the Unit Owners shall be the same as the undivided shares in the Common Elements appurtenant to the Owner's Units prior to the termination as set forth in Exhibit "B" hereto.

E. **Amendment.** This Article XX cannot be amended without consent of all Unit Owners and of all owners of mortgages required to approve termination by agreement.

## XXI. **CONDEMNATION.**

A. **General.** Whenever all or any part of the Condominium Property shall be taken by any authority having the power of condemnation or eminent domain, each Unit Owner shall be entitled to notice thereof and to participate in the proceedings incident thereto unless otherwise prohibited by law. The award made for such taking shall be payable to the Association if such award amounts to less than Five Thousand and no/100 Dollars (\$5,000.00) and to the Insurance Trustee if such award amounts to Five Thousand and no/100 Dollars (\$5,000.00) or more. Unless otherwise provided by law at the time of such taking, any award made therefor shall be disbursed by the Association or the Insurance Trustee, as the case may be, as hereinafter provided in this Article XXI.

B. Common Elements. In the event of a taking by eminent domain of part or all of the Common Elements, if seventy-five percent (75%) or more of the Unit Owners approve the repair and restoration of such Common Elements, the Board of Directors shall arrange for the repair and restoration of such Common Elements, and the Board of Directors or the Insurance Trustee, as the case may be, shall disburse the proceeds of such award to the contractors engaged in such repair and restoration in appropriate progress payments. In the event that seventy-five percent (75%) or more of the Unit Owners do not approve the repair and restoration of such Common Elements or if no repair or restoration is required, the Board of Directors or the Insurance Trustee, as the case may be, shall disburse the net proceeds of such award in the same manner as they are required under this Declaration to distribute insurance proceeds where such proceeds exceed the cost of repair or restoration of the damage.

C. Condemnation of a Unit or Part of a Unit. Where all or part of a Unit has been taken by eminent domain and seventy-five percent (75%) or more of the Unit Owners duly approve the repair and restoration of the Residential Building and Common Elements, the Board of Directors shall adjust such loss with the affected Unit Owner including, but not limited to, the payment of compensation and reduction or elimination of the Unit Owner's undivided interest in the Common Elements. Any such settlement shall not be effective unless approved by the mortgagee(s) of the affected Unit, a majority of the Unit Owners, and Developer, if Developer shall then own two or more Units in the Condominium. In no event shall the Board of Directors be required to make any payment in excess of that portion of the over-all condemnation award that is reasonably attributable to the particular Unit Owner's loss. In no event shall the Board of Directors be required to make any payment pursuant to the terms of this section prior to receipt of sufficient funds by the Board for such purpose from the condemning authority or Insurance Trustee. However, nothing contained in this section shall be deemed to prohibit the Board of Directors from making an advance or partial payment to such Unit Owner when the Board, in its discretion, deems such advance or partial payment to be reasonable and proper. Nothing contained in this section shall be deemed to relieve such Unit Owner of the obligation to contribute to repair or restoration of the Building and Common Elements as elsewhere provided, although the Board of Directors may, in a proper case, reduce the amount of such obligation or eliminate the same.

D. Notice to Mortgagees. The Board of Directors immediately upon having knowledge of the institution, or threat of institution, of any proceedings or other action with respect to the taking of Units or Common Elements, or any portion thereof in condemnation, eminent domain, or other proceedings or actions involving any unit of government or any other person having power of eminent domain, shall notify all mortgagees holding liens on five (5) or more Units. Such mortgagee may, at its option, if permitted by the court, participate in any such proceedings or actions or, in any event, may, at its option, participate in negotiations in connection therewith, but shall have no obligation to do so.

**XXII. RIGHTS OF DEVELOPER TO SELL UNITS.**

So long as Developer, or any mortgagee succeeding Developer in title, shall own any Unit, it shall have the right to sell any such Unit to any person, firm or corporation, or other entity upon any terms and conditions as it shall deem to be in its own best interests.

**XXIII. RIGHTS OF INSTITUTIONAL MORTGAGEES.**

Any mortgagee of a Unit who makes a request in writing to the Association for the items provided in this section shall have the following rights:

A. To be furnished with at least one (1) copy of the Annual Financial Statement and Report of the Association, including a detailed statement of annual income collected and operating expenses, such Financial Statement and Report to be furnished within sixty (60) days following the end of each fiscal year.

B. To be given written notice by the Association of the call of a meeting of the membership to be held for the purpose of considering any proposed amendment to this Declaration of Condominium, or the Articles of Incorporation and Bylaws of Association, which notices shall state the nature of the amendment being proposed.

C. To be given notice of default by any member owning any Unit encumbered by a mortgage held by such mortgagee, such notice to be given in writing and to be sent to the principal office of such mortgagee or to the place which it or they may designate in writing to the Association.

D. To be given an endorsement to the insurance policies covering the Common Elements requiring that such mortgagee be given any notice of cancellation provided for in such policy.

E. Regardless of any provision to the contrary contained in this Declaration, unless at least seventy-five percent (75%) of the Institutional First Mortgagees (based upon one vote for each loan secured by a first mortgage of individual Units in the Condominium Property) have given their prior written approval, the Association shall not be entitled to:

1. by act or omission seek to abandon, partition, subdivide, encumber, sell or transfer real estate or improvements thereon owned directly or indirectly by the Association. The granting of easements for public utilities or for other purposes consistent with the intended use of the Property shall not be deemed a transfer within the meaning of this clause;

2. change the method of determining the obligations, assessments, dues or other charges which may be assessed against any Units by the Association; and



3. by act or omission change, waive or abandon the regulations or enforcement thereof contained in this Declaration pertaining to the architectural design or the exterior appearance of Units, or the maintenance of the Units and Common Elements.

F. Examine Books and Records. Institutional First Mortgagees shall have the right to examine the books and records of the Association upon reasonable notice during ordinary working hours. The Association shall make available to Purchasers of Units and Institutional First Mortgagees current copies of this Declaration, the Articles of Incorporation, Bylaws and other rules governing the Association.

G. Taxes and Other Charges. In the event the Association fails to pay, when due, taxes assessed against the Common Elements or premiums of insurance covering the improvements on the Common Elements, then any one or more of said Institutional First Mortgagees may pay such taxes or insurance premiums, and the Association shall be obligated to reimburse such Institutional First Mortgagee or mortgagees for such payments, and until paid, the same shall constitute a lien upon the Common Elements in favor of the party or parties, entity or entities, paying same, which said lien may be enforced in a court of competent jurisdiction of the State of Florida in the same manner as a judgment lien may be enforced.

H. Definition of Institutional Mortgagee and Institution Lender. As used in this Article XXIII and throughout this Declaration the terms Institutional Mortgagee and Institutional Lender shall include a commercial or savings bank, trust company, insurance company, savings and loan association, pension fund, governmental agency or other such institutional lender, and institutional purchases of first mortgages on the secondary mortgage market, including without limitation, Federal National Mortgage Association ("FNMA").

#### XXIV. MISCELLANEOUS.

A. Severability. The invalidity in whole or in part of any covenant or restriction, or any article, subarticle, sentence, clause, phrase or word or other provision of this Declaration of Condominium and the Articles of Incorporation, Bylaws and regulations of the Association shall not affect the validity of the remaining portions thereof.

B. Applicability of Declaration of Condominium. All present or future owners, tenants or any other person who might use the facilities of the Condominium in any manner, are subject to the provisions of this Declaration, and the mere acquisition or rental of any Unit, or mere act of occupancy of any Unit, shall signify that the provisions of this Declaration of Condominium are accepted and ratified in all respects.

C. Construction. The provisions of this Declaration shall be liberally construed to effectuate its purpose of creating a uniform plan of Condominium ownership. The Florida Condominium Act as amended to the date hereof is hereby adopted and made a part hereof. In the event of any conflict between the provisions of this Declaration and the Condominium Act, the provisions of the Condominium Act shall prevail.

D. Assignment by Developer. Developer shall have the right to assign any or all of its interest in the Condominium Property and rights and obligations under this Declaration without consent of any Unit Owner or the Association.

E. Parties Bound. The restrictions and burdens imposed by this Declaration of Condominium are intended to and shall constitute covenants running with the Land and shall constitute an equitable servitude upon each Unit and its appurtenant undivided interest in Common Elements. This Declaration shall be binding upon Developer, its successors and assigns, and upon all parties who may subsequently become Unit Owners in the Condominium, the Association and their respective heirs, legal representatives, successors and assigns.

**IN WITNESS WHEREOF**, Developer has caused the foregoing Declaration of Condominium to be executed, and its corporate seal to be affixed, by its duly authorized officer on the date set forth above.

Signed, sealed and delivered  
in the presence of:

**DUNSFORD TERRACE APARTMENTS,  
LLC**, a Georgia limited liability company

  
\_\_\_\_\_  
Print Name Tom Thoman

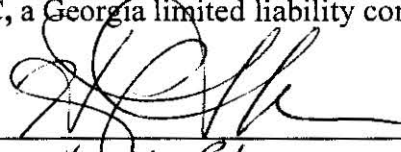
By:   
\_\_\_\_\_  
Print Name Headly Plover  
Its: MANAGING MEMBER

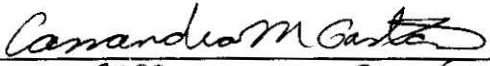
  
\_\_\_\_\_  
Print Name CASSANDRA M. GASTIN

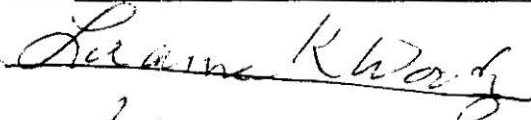
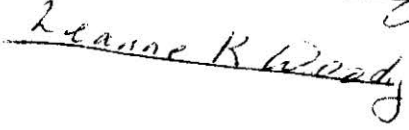
  
\_\_\_\_\_  
  
\_\_\_\_\_  
Leanne K. Woody





**EXHIBIT "A"**

**(Legal Description)**

**Lots 2, 3, 4, 5 and 6, Dunsford Terrace, as recorded in Plat Book 33, Page 52 of the public records of Duval County, Florida.**

EXHIBIT "B"

**(Common Elements and Common Surplus)**

The undivided share in the Common Elements and Common Surplus appurtenant to each Unit shall equal One Thirtieth (1/30).

EXHIBIT "C"

(Plot Plan and Survey)

# MAP SHOWING SURVEY OF: CITYHOMES AT SAN MARCO - A CONDOMINIUM

Book 10308 Page 2347

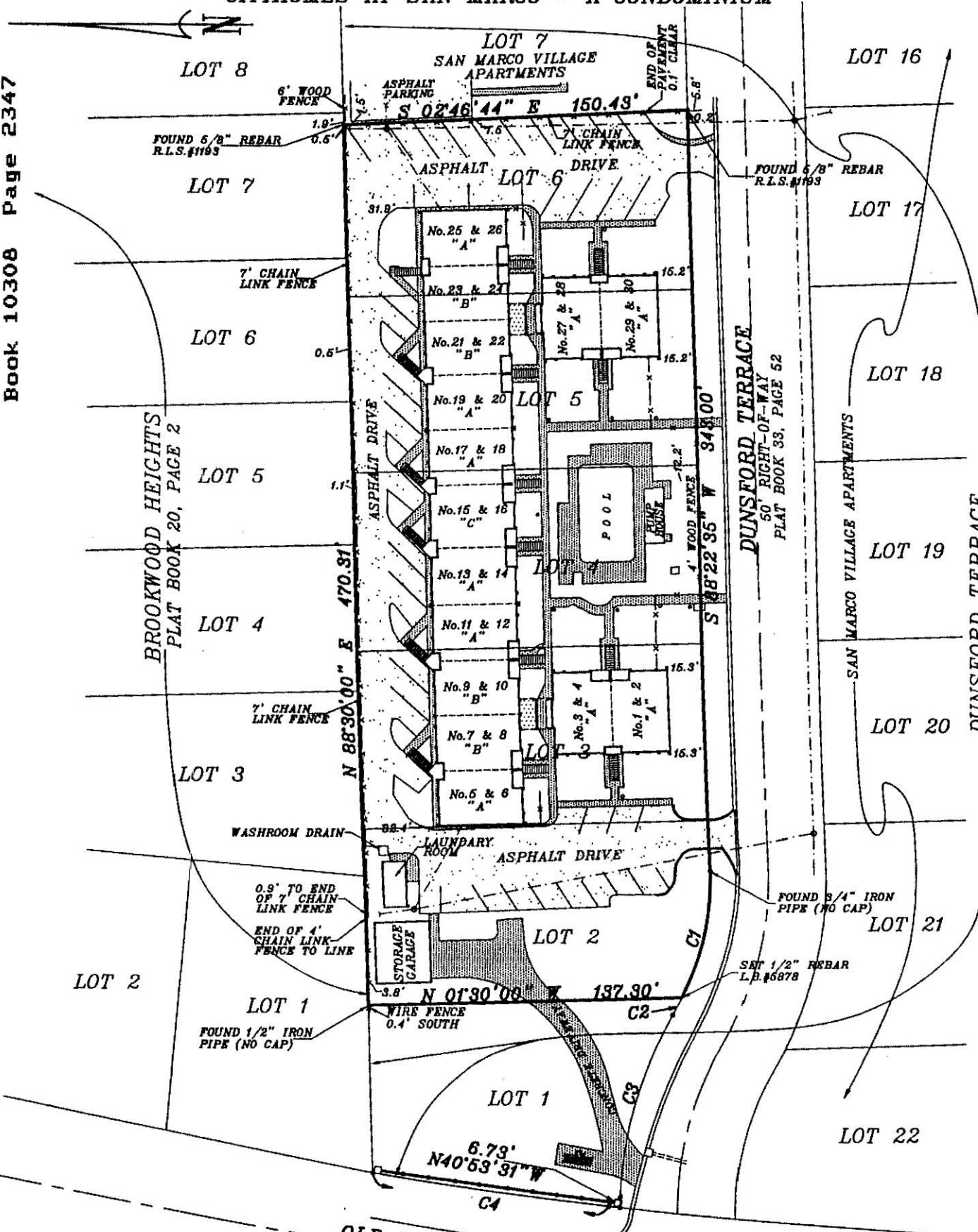

CURVE	DELTA	RADIUS	ARC	CHORD	CHORD BEARING
C1	27°29'14"	124.16	69.68	68.99	N 77°54'45" W
C2	3°59'10"	124.16	8.64	8.64	N 82°10'37" W
C3	27°36'38"	174.16	83.87	83.06	N 73°58'45" W
C4	2°44'38"	2179.45	104.39	104.38	S 08°15'11" W

- NOTES:**
- 1) THIS IS A BOUNDARY SURVEY.
  - 2) BEARINGS ARE BASED ON THE CENTERLINE OF OLD ST. AUGUSTINE ROAD AS BEING N 11°19'47" W.
  - 3) THIS PROPERTY APPEARS TO LIE IN FLOOD ZONE "X" WHICH IS THE AREA OUTSIDE THE 500 YEAR FLOOD BY FLOOD MAPS REVISED AUGUST 15, 1989, COMMUNITY PANEL No. 120077 0144 E.
  - 4) THERE IS A 15 FOOT FRONT BUILDING RESTRICTION LINE ACCORDING TO THE PLAT OF DUNSFORD TERRACE.
  - 5) ALL BUILDINGS ARE MASONRY (CONCRETE BLOCK), ALL RESIDENTIAL BUILDINGS ARE 2-STORY.
  - 6) FOR DETAILED SURVEY OF THIS PROPERTY SEE SIZEMOR & ASSOC. SURVEY DATED 12-7-1999, DRAWING No. M-60.
  - 7) NUMBERS SHOWN THUS: No. 5 DESIGNATES UNIT NUMBERS AND LETTERS SHOWN THUS: A DESIGNATE UNIT TYPE.
  - 8) SEE SHEET 3 OF 3 SHEETS FOR LEGAL DESCRIPTION & CONDOMINIUM CERTIFICATION.

EXHIBIT C, PAGE 1  
SHEET 1 OF 3 SHEETS

I HEREBY CERTIFY TO: \_\_\_\_\_  
REALTY ASSET MANAGEMENT, INC.

THAT THIS SURVEY MEETS THE MINIMUM TECHNICAL STANDARDS AS SET FORTH BY THE FLORIDA BOARD OF SURVEYORS AND MAPPERS, PURSUANT TO SECT 472.027 FLORIDA STATUTES AND CHAPTER 61C17-6 FLORIDA ADMINISTRATION CODE.

*Jerry Sizemore*  
FLORIDA REGISTERED SURVEYOR NO. 4177  
JERRY M. SIZEMOR

SIGNED \_\_\_\_\_ APRIL 17, 2000  
SCALE: \_\_\_\_\_ 1" = 60'

UNLESS IT BEARS THE SIGNATURE AND THE ORIGINAL RAISED SEAL OF A FLORIDA LICENSED SURVEYOR AND MAPPER THIS MAP IS FOR INFORMATIONAL PURPOSES ONLY AND IS NOT VALID

## SIZEMORE AND ASSOCIATES INC.

**SURVEYING & MAPPING**

LICENSED BUSINESS #6878      5949 MACY AVENUE  
JACKSONVILLE, FLORIDA 32211      (904) 744-8011

10909 1269d

# ELEVATIONS:

## CITYHOMES AT SAN MARCO - A CONDOMINIUM

Book 10308 Page 2348

### ELEVATIONS UNITS 1 - 4

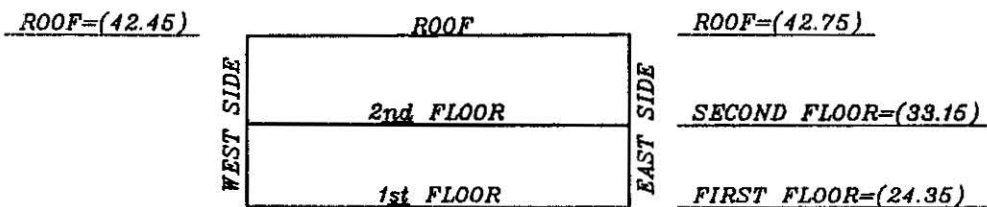

### ELEVATIONS UNITS 5 - 26

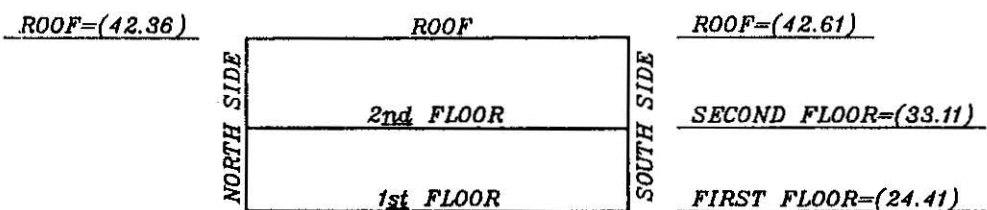

### ELEVATIONS UNITS 27 - 30

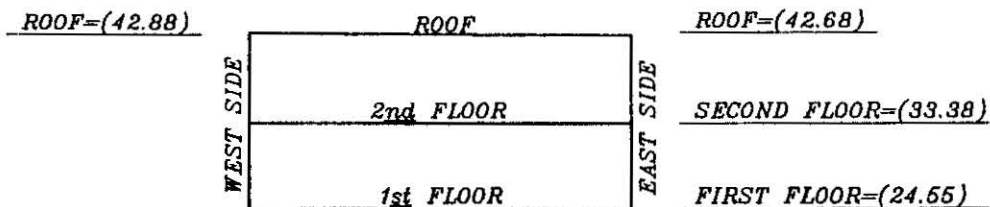

### LAUNDRY ROOM

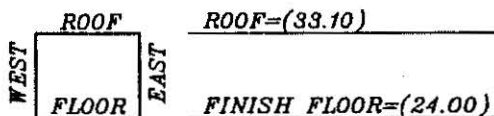

**NOTES:**

- 1) ELEVATIONS SHOWN THUS: (23.95) REFER TO THE NATIONAL GEODETIC VERTICAL DATUM OF 1929.
- 2) CONDOMINIUM UNIT OWNERSHIP EXTENDS FROM INSIDE FACE OF WALL TO FINISHED FLOOR SURFACE AND TO FINISHED CEILING SURFACE OF EACH UNIT.
- 3) RECESSED DOORWAYS AND PATIOS ARE LIMITED COMMON AREAS, ALL OTHERS EXCEPT UNITS ARE COMMON AREAS OF THE CONDOMINIUM.

EXHIBIT   C   PAGE   2    
SHEET 2 OF 3 SHEETS



**SIZEMORE AND ASSOCIATES INC.**  
SURVEYING & MAPPING

6949 MACY AVENUE  
JACKSONVILLE, FLORIDA 32211  
(904) 744-8011

LICENSED BUSINESS #5878

DATE:   NOVEMBER 20, 2000    
SCALE:   1" = 20'



CITIHOMES AT SAN MARCO - A CONDOMINIUM

Book 10308 Page 2349

LOTS 2, 3, 4, 5, AND 6, DUNSFORD TERRACE, AS RECORDED IN PLAT BOOK 33, PAGE 52 OF THE CURRENT PUBLIC RECORDS OF DUVAL COUNTY, FLORIDA.

EXHIBIT " C "
TO
DECLARATION OF CONDOMINIUM

CITIHOMES AT SAN MARCO - A CONDOMINIUM

ATTACHED HERETO AS EXHIBIT "C" THE SURVEY OF LOTS 2, 3, 4, 5, AND 6, DUNSFORD TERRACE TO THE CONDOMINIUM PROPERTY.

CERTIFICATION

This is to certify that the construction of the improvements of Citihomes At San Marco, A Condominium are substantially complete so that this material, together with the provisions of the Declaration describing the Condominium Property and Exhibits A, C and D are an accurate representation of the location and exterior dimensions of the improvements so that the Common Elements and each unit can be determined from these materials.

Jerry Sizemore
JERRY M. SIZEMORE

REGISTERED SURVEYOR No. 4177
STATE OF FLORIDA

SIGNED: APRIL 17, 2000

EXHIBIT C, PAGE 3

SHEET 3 OF 3 SHEETS

I HEREBY CERTIFY TO: Realty Asset Management, Inc.

THAT THIS SURVEY MEETS THE MINIMUM TECHNICAL STANDARDS AS SET FORTH BY THE FLORIDA BOARD OF SURVEYORS AND MAPPERS, PURSUANT TO SECTION 472.027 FLORIDA STATUTES AND CHAPTER 61G17-6 FLORIDA ADMINISTRATION CODE.

Jerry Sizemore
FLORIDA REGISTERED SURVEYOR NO. 4177
JERRY M. SIZEMORE

SIGNED APRIL 17, 2000

SCALE: 1" = 20'

UNLESS IT BEARS THE SIGNATURE AND THE ORIGINAL RAISED SEAL OF A FLORIDA LICENSED SURVEYOR AND MAPPER THIS MAP IS FOR INFORMATIONAL PURPOSES ONLY AND IS NOT VALID

SIZEMORE AND ASSOCIATES INC. SURVEYING & MAPPING
6849 MACY AVENUE JACKSONVILLE, FLORIDA 32211 (904) 744-8011
LICENSED BUSINESS #6878

# FLOOR PLANS.

CITYHOMES AT SAN MARCO - A CONDOMINIUM

Book 10308 Page 2350

DOWNSTAIRS UNIT TYPE "A"  
FINISH FLOOR ELEVATION=(24.41)

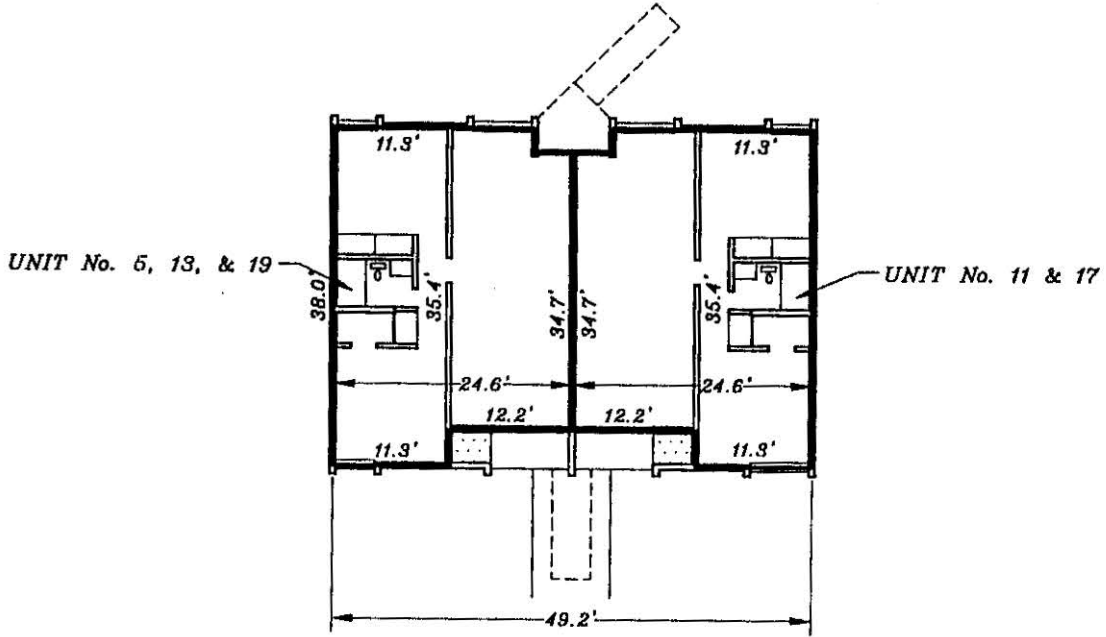

UPSTAIRS UNIT TYPE "A"  
FINISH FLOOR ELEVATION=(33.11)

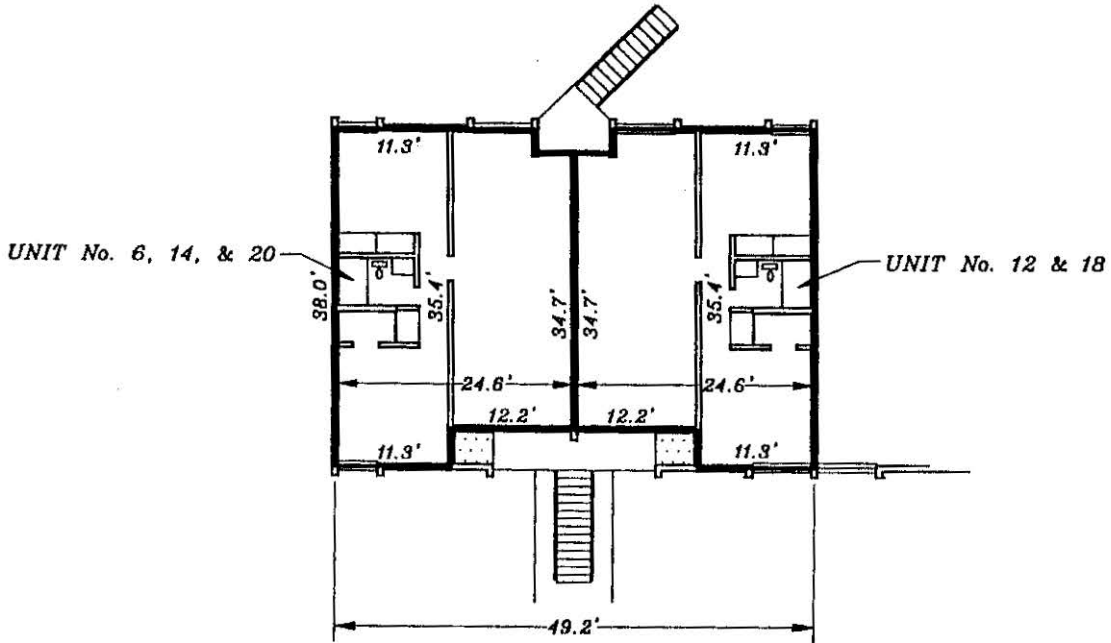

LAUNDRY ROOM  
FINISH FLOOR  
ELEVATION=(24.00)

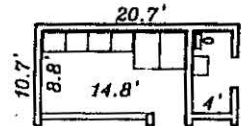

EXHIBIT \_\_\_\_\_ PAGE 1  
SHEET 1 OF 8 SHEETS

**NOTES:**

- 1) UNIT BOUNDARIES ARE DESIGNATED BY HEAVY LINES AND EXTEND TO FINISHED INSIDE WALL OF THE UNIT.
- 2) LIMITED COMMON AREAS ARE SHOWN THUS: HATCHED, ALL OTHER AREAS ARE COMMON AREAS.
- 3) ALL INTERIOR DIMENSIONS ARE APPROXIMATE, NONE WERE MEASURED.
- 4) SEE SHEET 9 OF 9 SHEETS FOR FLOOR PLAN OPTIONS.
- 5) ELEVATIONS SHOWN THUS: (23.95) REFER TO THE NATIONAL GEODETIC VERTICAL DATUM OF 1929.

NUMBERS SHOWN THUS: No.5 DESIGNATE UNIT NUMBERS AND LETTERS SHOWN THUS: "A" DESIGNATE UNIT TYPE PER ARCHITECTS FLOOR PLAN.

**IZEMORE AND ASSOCIATES INC.**  
SURVEYING & MAPPING  
LICENSED BUSINESS #5878  
5949 MACY AVENUE  
JACKSONVILLE, FLORIDA 32211  
(904) 744-8011

DATE: MAY 10, 2000  
SCALE: 1" = 20'

# FLOOR PLANS

CITYHOMES AT SAN MARCO - A CONDOMINIUM

DOWNSTAIRS UNIT TYPE "A"  
FINISH FLOOR ELEVATION=(24.55)

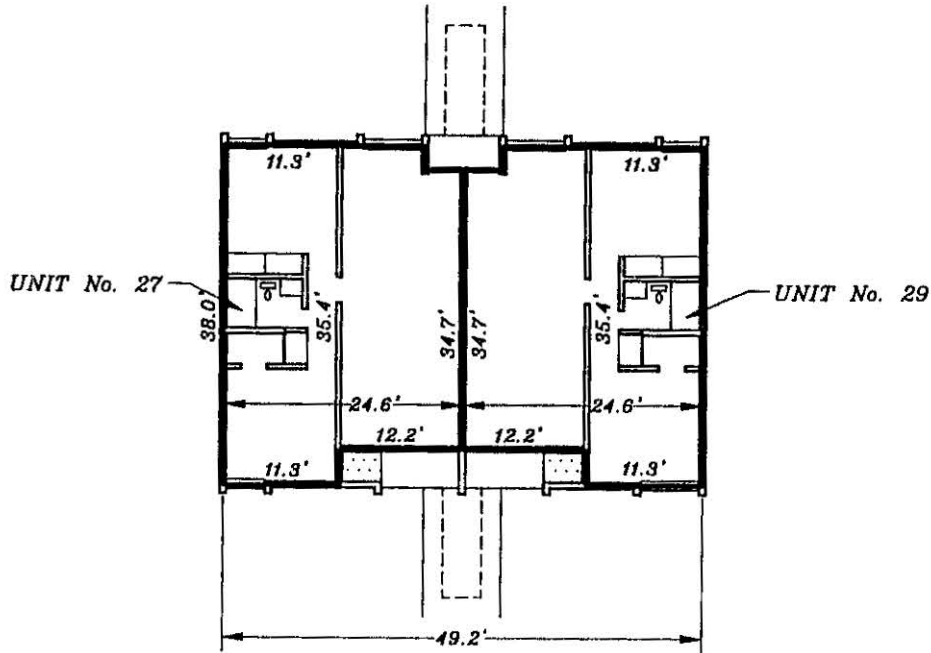

UPSTAIRS UNIT TYPE "A"  
FINISH FLOOR ELEVATION=(33.38)

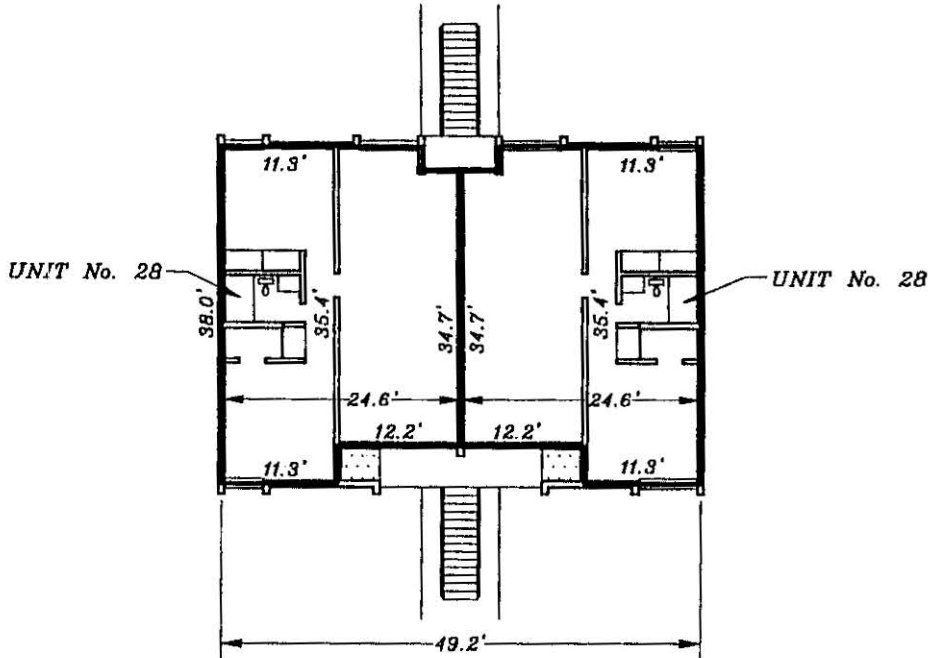

**NOTES:**

- 1) UNIT BOUNDARIES ARE DESIGNATED BY HEAVY LINES AND EXTEND TO FINISHED INSIDE WALL OF THE UNIT.
- 2) LIMITED COMMON AREAS ARE SHOWN THUS: HATCHED, ALL OTHER AREAS ARE COMMON AREAS.
- 3) ALL INTERIOR DIMENSIONS ARE APPROXIMATE, NONE WERE MEASURED.
- 4) SEE SHEET 9 OF 9 SHEETS FOR FLOOR PLAN OPTIONS.
- 5) ELEVATIONS SHOWN THUS: (23.95) REFER TO THE NATIONAL GEODETIC VERTICAL DATUM OF 1929.

EXHIBIT \_\_\_\_\_, PAGE 2  
SHEET 2 OF 8 SHEETS

NUMBERS SHOWN THUS: No.5 DESIGNATE UNIT NUMBERS AND LETTERS SHOWN THUS: "A" DESIGNATE UNIT TYPE PER ARCHITECTS FLOOR PLAN.

**SIZEMORE AND ASSOCIATES INC.**  
SURVEYING & MAPPING  
5949 MACY AVENUE  
JACKSONVILLE, FLORIDA 32211  
(904) 744-8011

LICENSED BUSINESS #5878

DATE: MAY 10, 2000  
SCALE: 1" = 20'

# FLOOR PLANS:

## CITYHOMES AT SAN MARCO - A CONDOMINIUM

Book 10308 Page 2352

### DOWNSTAIRS UNIT TYPE "A" FINISH FLOOR ELEVATION=(24.35)

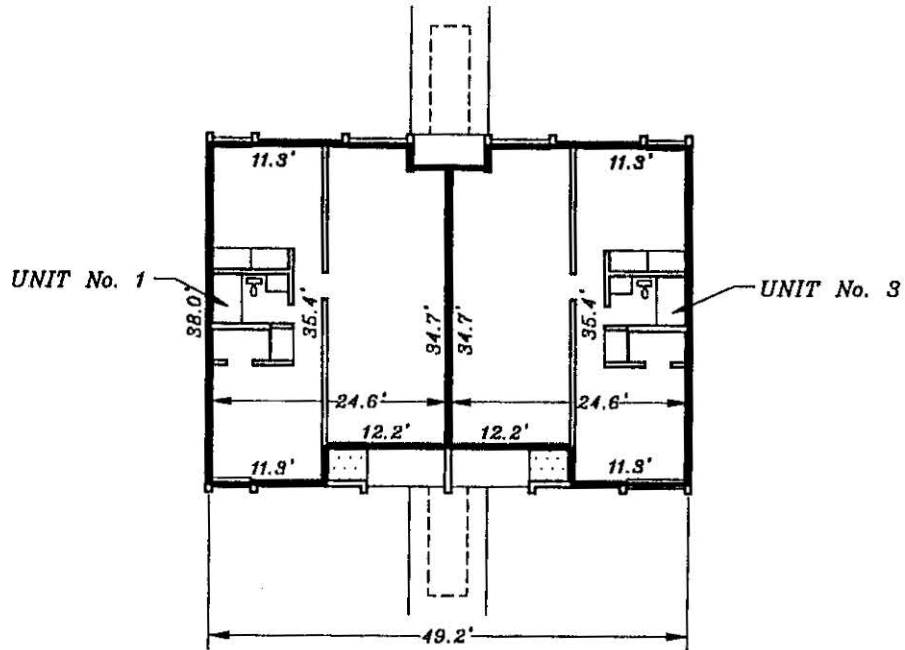

### UPSTAIRS UNIT TYPE "A" FINISH FLOOR ELEVATION=(33.15)

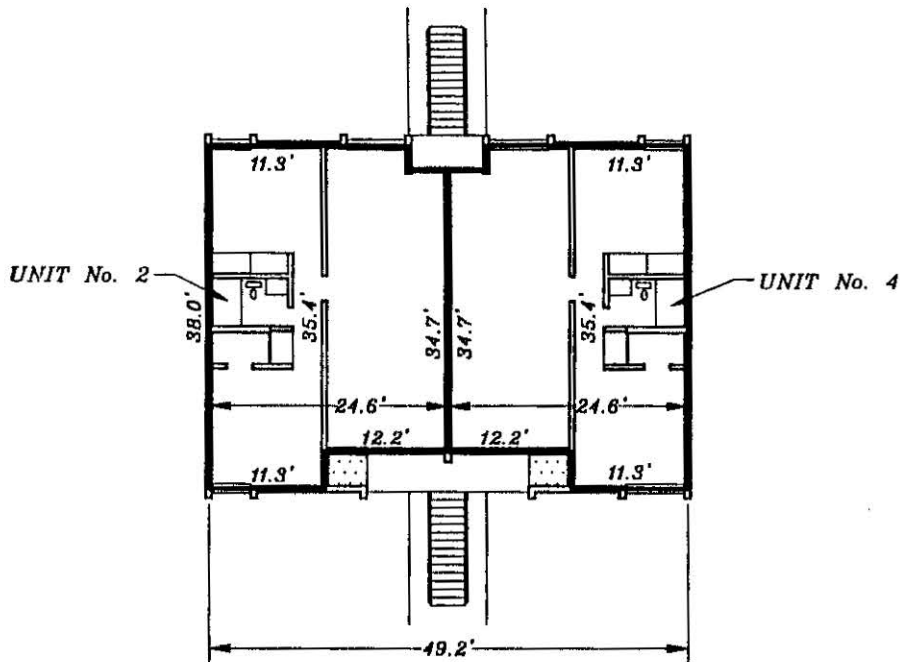

**NOTES:**

- 1) UNIT BOUNDARIES ARE DESIGNATED BY HEAVY LINES AND EXTEND TO FINISHED INSIDE WALL OF THE UNIT.
- 2) LIMITED COMMON AREAS ARE SHOWN THUS:  HATCHED, ALL OTHER AREAS ARE COMMON AREAS.
- 3) ALL INTERIOR DIMENSIONS ARE APPROXIMATE, NONE WERE MEASURED.
- 4) SEE SHEET 9 OF 9 SHEETS FOR FLOOR PLAN OPTIONS.
- 5) ELEVATIONS SHOWN THUS: (23.95) REFER TO THE NATIONAL GEODETIC VERTICAL DATUM OF 1929.

EXHIBIT \_\_\_\_\_, PAGE 3  
SHEET 3 OF 8 SHEETS

NUMBERS SHOWN THUS: No.5 DESIGNATE UNIT NUMBERS AND LETTERS SHOWN THUS: "A" DESIGNATE UNIT TYPE PER ARCHITECTS FLOOR PLAN.

**SIZEMORE AND ASSOCIATES INC.**  
SURVEYING & MAPPING  
6949 MACY AVENUE  
JACKSONVILLE, FLORIDA 32211  
(904) 744-8011

LICENSED BUSINESS #5878

DATE: MAY 10, 2000  
SCALE: 1" = 20'

# FLOOR PLANS.

CITIHOMES AT SAN MARCO - A CONDOMINIUM

Book 10308 Page 2353

UNIT No. 25  
DOWNSTAIRS UNIT TYPE "A"  
FINISH FLOOR ELEVATION=(24.41)

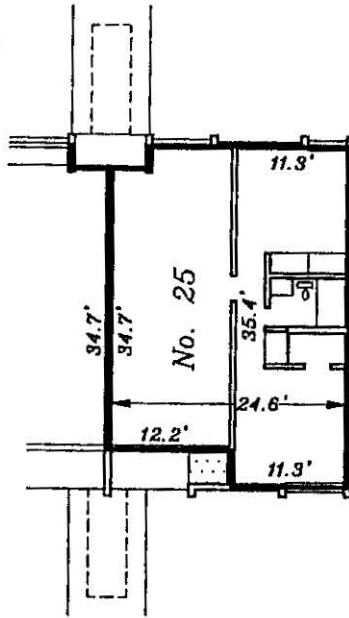

UNIT No. 26  
UPSTAIRS UNIT TYPE "A"  
FINISH FLOOR ELEVATION=(33.11)

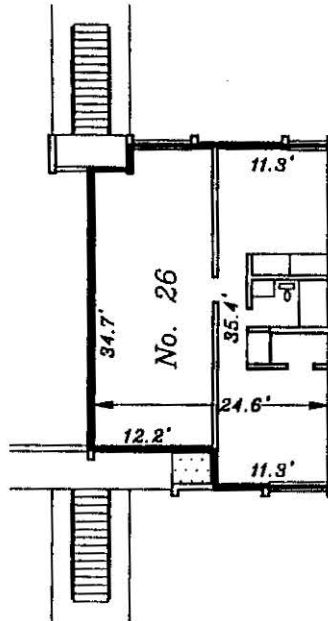

**NOTES:**

- 1) UNIT BOUNDARIES ARE DESIGNATED BY HEAVY LINES AND EXTEND TO FINISHED INSIDE WALL OF THE UNIT.
- 2) LIMITED COMMON AREAS ARE SHOWN THUS:  HATCHED, ALL OTHER AREAS ARE COMMON AREAS.
- 3) ALL INTERIOR DIMENSIONS ARE APPROXIMATE, NONE WERE MEASURED.
- 4) SEE SHEET 9 OF 9 SHEETS FOR FLOOR PLAN OPTIONS.
- 5) ELEVATIONS SHOWN THUS: (23.95) REFER TO THE NATIONAL GEODETIC VERTICAL DATUM OF 1929.

EXHIBIT \_\_\_\_\_ PAGE 4  
SHEET 4 OF 8 SHEETS

NUMBERS SHOWN THUS: No.5 DESIGNATE UNIT NUMBERS AND LETTERS SHOWN THUS: "A" DESIGNATE UNIT TYPE PER ARCHITECTS FLOOR PLAN.

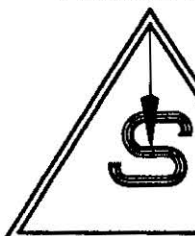

**SIZEMORE AND ASSOCIATES INC.**  
SURVEYING & MAPPING  
6949 MACY AVENUE  
JACKSONVILLE, FLORIDA 32211  
(904) 744-8011  
LICENSED BUSINESS #5878

DATE: MAY 10, 2000  
SCALE: 1" = 20'



# FLOOR PLANS.

CITIHMES AT SAN MARCO - A CONDOMINIUM

Book 10308 Page 2354

UNIT No.15  
DOWNSTAIRS UNIT TYPE "C"  
FINISH FLOOR ELEVATION=(24.41)

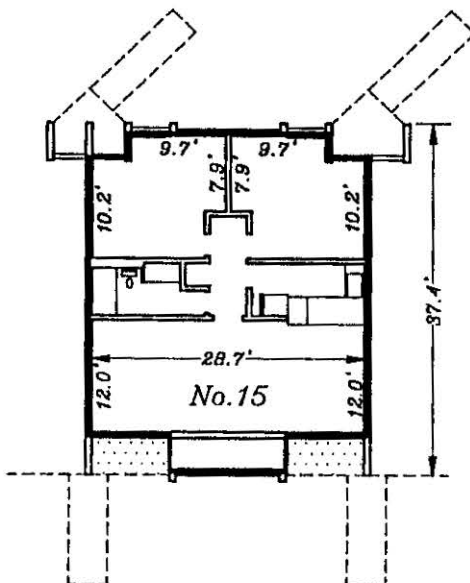

UNIT No.16  
UPSTAIRS UNIT TYPE "C"  
FINISH FLOOR ELEVATION=(33.11)

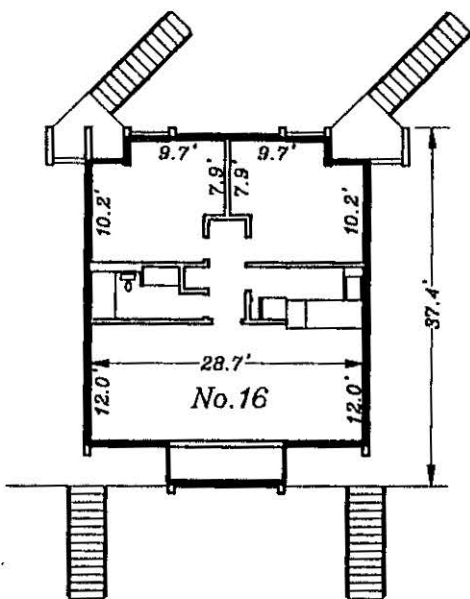

**NOTES:**

- 1) UNIT BOUNDARIES ARE DESIGNATED BY HEAVY LINES AND EXTEND TO FINISHED INSIDE WALL OF THE UNIT.
- 2) LIMITED COMMON AREAS ARE SHOWN THUS:  HATCHED, ALL OTHER AREAS ARE COMMON AREAS.
- 3) ALL INTERIOR DIMENSIONS ARE APPROXIMATE, NONE WERE MEASURED.
- 4) SEE SHEET 9 OF 9 SHEETS FOR FLOOR PLAN OPTIONS.
- 5) ELEVATIONS SHOWN THUS: (23.95) REFER TO THE NATIONAL GEODETIC VERTICAL DATUM OF 1929.

EXHIBIT \_\_\_\_\_ PAGE 5  
SHEET 5 OF 8 SHEETS

NUMBERS SHOWN THUS: No.5 DESIGNATE UNIT NUMBERS AND LETTERS SHOWN THUS: "A" DESIGNATE UNIT TYPE PER ARCHITECTS FLOOR PLAN.



**SIZEMORE AND ASSOCIATES INC.**  
SURVEYING & MAPPING

6949 MACY AVENUE  
JACKSONVILLE, FLORIDA 32211  
(904) 744-8011

LICENSED BUSINESS #5878

DATE: MAY 10, 2000  
SCALE: 1" = 20'

# FLOOR PLANS.

CITYHOMES AT SAN MARCO - A CONDOMINIUM

Book 10308 Page 2355

DOWNSTAIRS UNIT TYPE "B"  
FINISH FLOOR ELEVATION=(24.41)

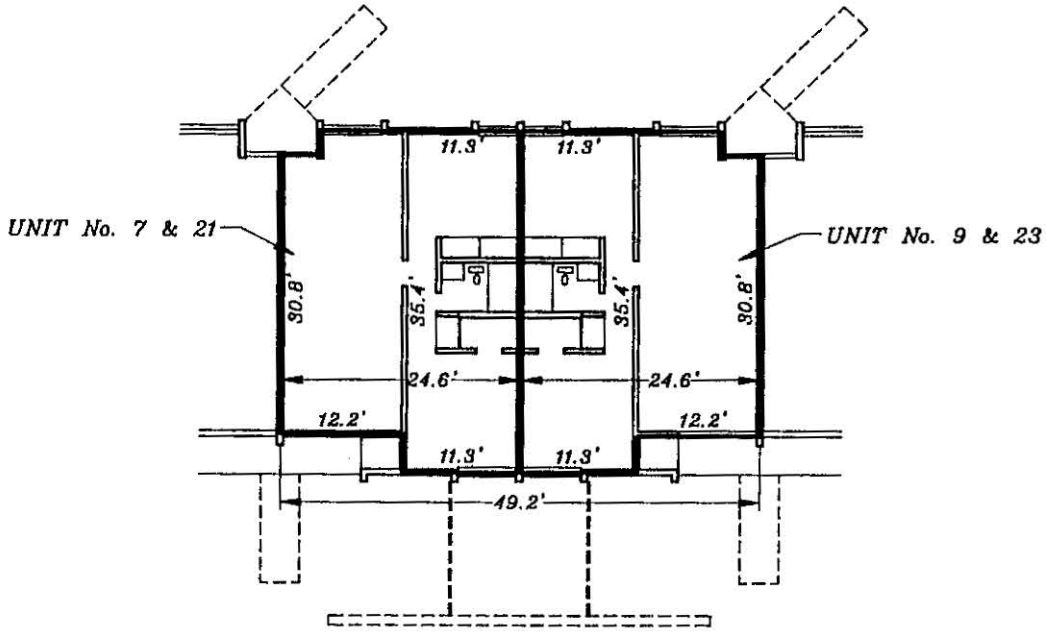

UPSTAIRS UNIT TYPE "B"  
FINISH FLOOR ELEVATION=(33.11)

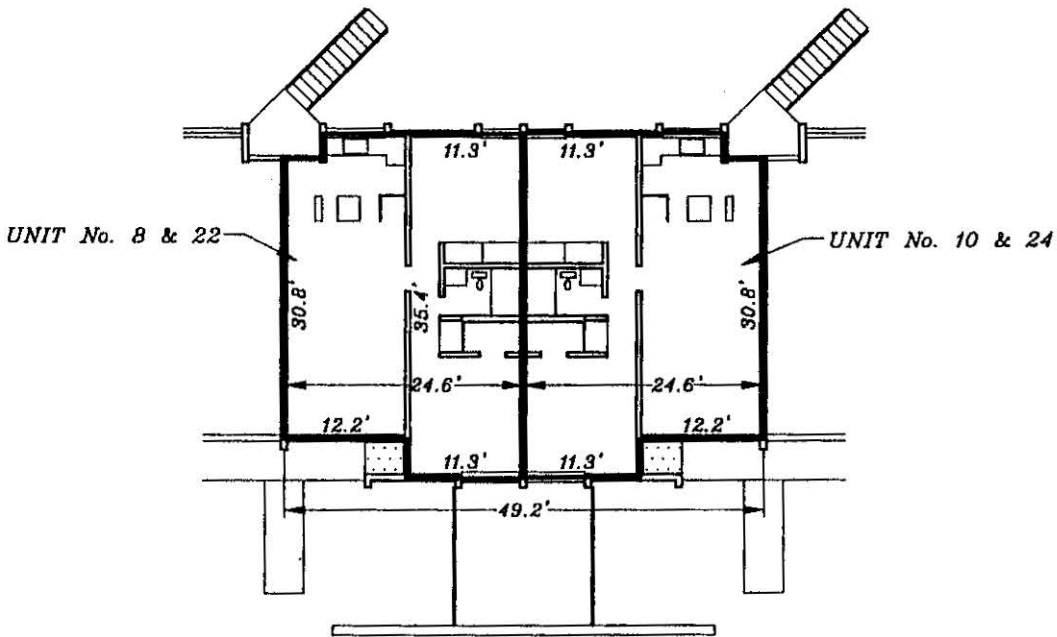

**NOTES:**

- 1) UNIT BOUNDARIES ARE DESIGNATED BY HEAVY LINES AND EXTEND TO FINISHED INSIDE WALL OF THE UNIT.
- 2) LIMITED COMMON AREAS ARE SHOWN THUS:  HATCHED, ALL OTHER AREAS ARE COMMON AREAS.
- 3) ALL INTERIOR DIMENSIONS ARE APPROXIMATE, NONE WERE MEASURED.
- 4) SEE SHEET 9 OF 9 SHEETS FOR FLOOR PLAN OPTIONS.
- 5) ELEVATIONS SHOWN THUS: (23.95) REFER TO THE NATIONAL GEODETIC VERTICAL DATUM OF 1929.

EXHIBIT \_\_\_\_\_ PAGE 6  
SHEET 6 OF 8 SHEETS

NUMBERS SHOWN THUS: No.5 DESIGNATE UNIT NUMBERS AND LETTERS SHOWN THUS: "A" DESIGNATE UNIT TYPE PER ARCHITECTS FLOOR PLAN.



**SIZEMORE AND ASSOCIATES INC.**  
SURVEYING & MAPPING

5949 MACY AVENUE  
JACKSONVILLE, FLORIDA 32211  
(904) 744-8011

LICENSED BUSINESS #5878

DATE: MAY 10, 2000  
SCALE: 1" = 20'

# OPTIONAL FLOOR PLANS:

CITYHOMES AT SAN MARCO - A CONDOMINIUM

Book 10308 Page 2356

OPTION "1"  
FOR TYPE "A"

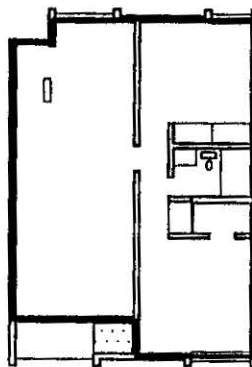
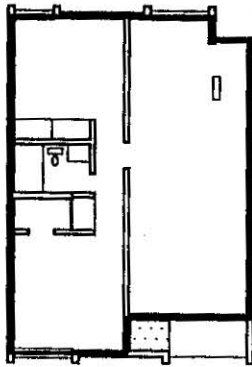

OPTION "2"  
FOR TYPE "A"

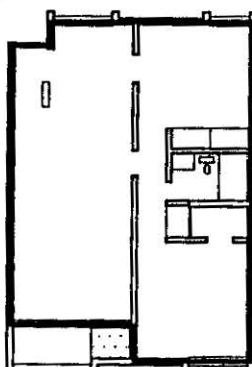
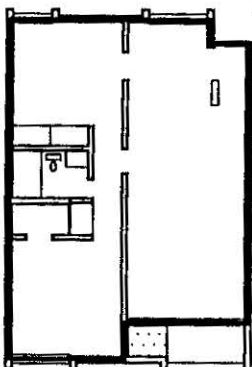

OPTION "3"  
FOR TYPE "A"

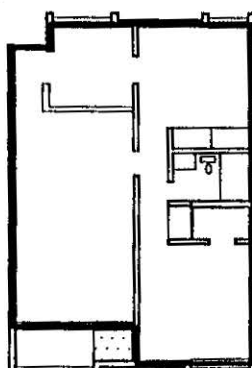
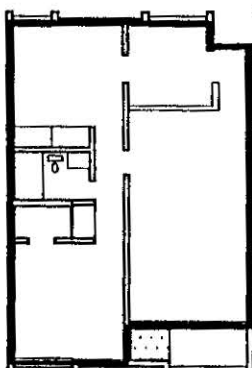

OPTION "4"  
FOR TYPE "A"

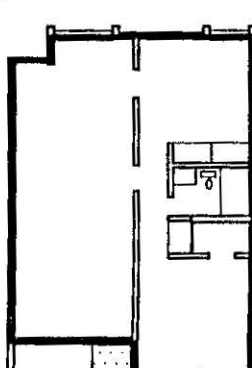
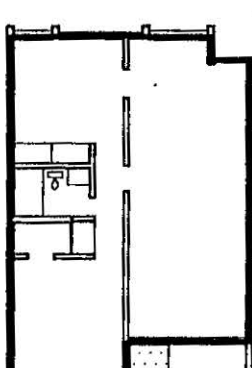

**SIZEMORE AND ASSOCIATES INC.**  
SURVEYING & MAPPING  
LICENSED BUSINESS #5878  
5949 MACY AVENUE  
JACKSONVILLE, FLORIDA 32211  
(904) 744-8011

EXHIBIT \_\_\_\_\_ PAGE 7  
SHEET 7 OF 8 SHEETS

DATE: NOVEMBER 20, 2000  
SCALE: 1" = 20'

# OPTIONAL FLOOR PLANS: CITYHOMES AT SAN MARCO - A CONDOMINIUM

Book 10308 Page 2357

OPTION "1"  
FOR TYPE "B"

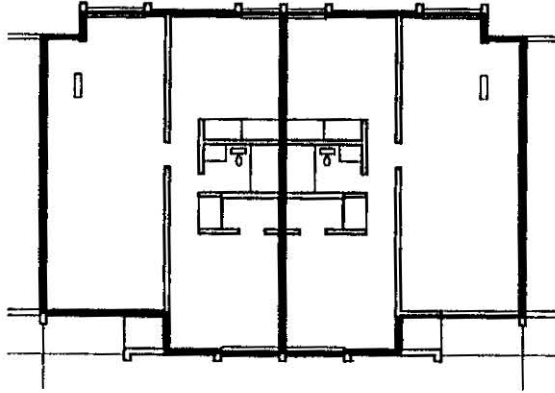

OPTION "2"  
FOR TYPE "B"

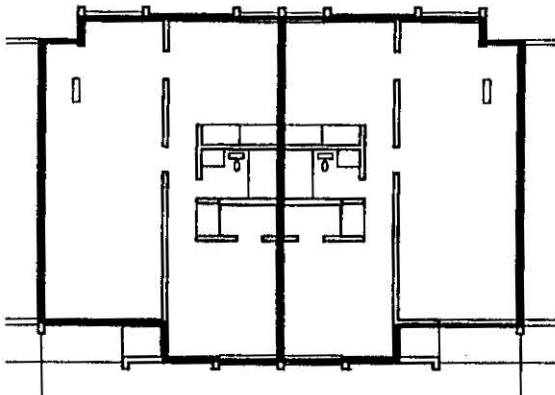

OPTION "3"  
FOR TYPE "B"

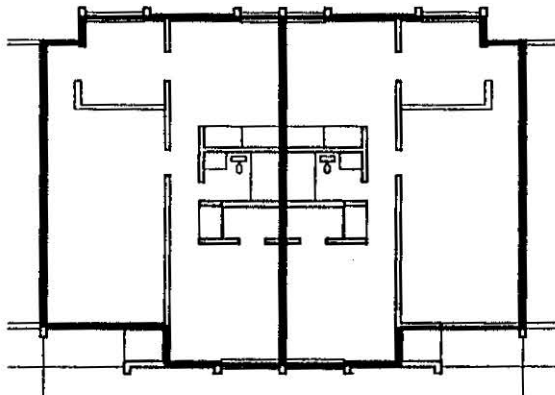

OPTION "4"  
FOR TYPE "B"

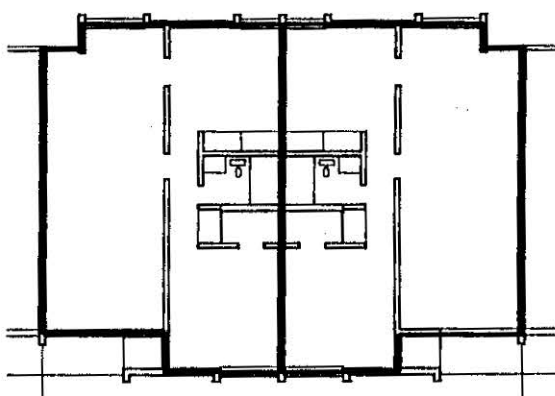



EXHIBIT \_\_\_\_\_, PAGE 8  
SHEET 8 OF 8 SHEETS

DATE: NOVEMBER 20, 2000  
SCALE: 1" = 20'

**SIZEMORE AND ASSOCIATES INC.**  
SURVEYING & MAPPING  
LICENSED BUSINESS #5078  
5949 MACY AVENUE  
JACKSONVILLE, FLORIDA 32211  
(904) 744-8011

**EXHIBIT "E"**

**(Articles of Incorporation of  
Citihomes at San Marco  
Condominium Association)**



**ARTICLES OF INCORPORATION**

**OF**

**CITIHOUSES AT SAN MARCO CONDOMINIUM ASSOCIATION, INC.  
a Florida corporation not-for-profit**

In order to form a corporation under the Laws of Florida for the formation of corporations not-for-profit we, the undersigned, hereby associate ourselves into a corporation for the purposes and with the powers herein specified, and to that end we do, by these Articles of Incorporation, set forth:

**ARTICLE I**

**NAME**

The name of the corporation shall be Citihomes at San Marco Condominium Association, Inc. ("Association").

**ARTICLE II**

**PURPOSE**

The purpose of the Association is the administration, operation and management of a condominium known as Citihomes at San Marco Condominium ("Condominium") as the same may now or hereafter be constituted, which Condominium is established pursuant to the Declaration of Condominium for Citihomes at San Marco Condominium ("Declaration") in accordance with the Florida Condominium Act, Chapter 718, *Florida Statutes* ("Act"). The Association shall undertake the performance of and shall carry out the acts and duties incident to the administration, operation and management of the Condominium in accordance with the terms, provisions and authorizations contained herein, in the Bylaws established pursuant to the requirements of these Articles and in the Declaration of Condominium which will be recorded in the public records of St. Johns County, Florida, and further, may exercise all powers granted to a condominium association under the Act. In addition, the Association may acquire, own, operate, lease, sell, trade or otherwise deal with any property, real or personal, as may become part of the Condominium ("Condominium Property") and as may be necessary or convenient for the administration of the Condominium. All defined terms contained these Articles shall have the same meanings as such terms are defined by the Declaration.

ARTICLE III

POWERS AND DUTIES

The Association shall have the following powers:

A. All of the powers and privileges granted to corporations not-for-profit under the law pursuant to which this Corporation is chartered.

B. All of the powers reasonably necessary to implement and effectuate the purposes of the Association including, without limitation, the power, authority and right to:

1. Make and establish reasonable rules and regulations governing use of the Units, Common Elements and Limited Common Elements in and of the Condominium, as such terms will be defined in the Declaration.

2. Levy and collect assessments against members of the Association to defray the Common Expenses of the Condominium, as provided in the Declaration and the Bylaws including, without limitation, the right to levy and collect assessments for the purposes of (i) acquiring, owning, holding, operating, leasing, encumbering, selling, conveying, exchanging, managing and otherwise dealing with the Condominium Property, including Units, which may be necessary or convenient in the operation and management of the Condominium, (ii) operating, maintaining and repairing the Surface Water or Stormwater Management System, and (iii) accomplishing the purposes set forth in the Declaration generally.

3. Maintain, repair, replace, operate and manage the Condominium Property, including the right to reconstruct improvements after casualty and to further improve and add to the Condominium Property.

4. Contract for the management of the Condominium and, in connection therewith, to delegate any and/or all of the powers and duties of the Association to the extent and in the manner permitted by the Declaration, the Bylaws and the Act.

5. Enforce the provisions of these Articles of Incorporation, the Declaration, the Bylaws and all rules and regulations governing use of the Condominium which may hereafter be established.

6. Exercise, undertake and accomplish all of the rights, duties and obligations which may be granted to or imposed upon the Association in the Declaration and the Act.

7. The Association shall operate, maintain and manage the Surface Water or Stormwater Management System in a manner consistent with all applicable permits issued by the St. Johns River Water Management District (the "District") and District Rules and shall assist in the enforcement of the restrictions and requirements contained therein.

#### ARTICLE IV

#### MEMBERSHIP

The qualifications of members, manner of their admission to and termination of membership and voting by members shall be as follows:

A. The owners of all Units in the Condominium shall be members of the Association and no other persons or entities shall be entitled to membership.

B. Membership shall be established by the acquisition of a fee title to a Unit in the Condominium, or by acquisition of a fee ownership interest therein, by voluntary conveyance or operation of law, and the membership of any person or entity shall be automatically terminated when such person or entity is divested of all title or his entire fee ownership in such Unit; provided, that nothing herein contained shall be construed as terminating the membership of any person or entity owning fee title to or a fee ownership interest in two (2) or more Units at any time while such person or entity shall retain fee title to or a fee ownership interest in any Unit.

C. The interest of a member in the funds and assets of the Association cannot be assigned, hypothecated or transferred in any manner, except as an appurtenance to the Unit(s) owned by such member. The funds and assets of the Association shall be expended, held or used only for the benefit of the membership and for the purposes authorized herein, in the Declaration and in the Bylaws.

D. On all matters upon which the membership is entitled to vote as hereinafter provided, there shall be one, and only one, vote for each Unit in the Condominium, which vote may be exercised or cast by the owner(s) of each Unit as provided for in the Bylaws. Should any member own more than one Unit, such member shall be entitled to exercise or cast one vote for each such Unit, in the manner provided for in the Bylaws.

E. Until such time as the parcel of real property within the Condominium Property and the improvements now and/or to be constructed thereon, are submitted to the Condominium form of ownership by recordation of a Declaration of Condominium therefor in the public records of Duval, Florida, the membership of the Association shall be comprised of the members of the first

Board of Directors as set forth in these Articles, each of whom shall be entitled to cast a vote on all matters upon which the membership would be entitled to vote.

**ARTICLE V**

**EXISTENCE**

Existence of the Association shall commence with the filing of these Articles of Incorporation with the Florida Secretary of State, Tallahassee, Florida. The Association shall have perpetual existence unless the Condominium is terminated pursuant to the provisions of its Declaration, in which event the Association shall be dissolved in accordance with law.

**ARTICLE VI**

**PRINCIPAL OFFICE**

The principal office of the Association shall be located at 2043 Dunsford Terrace, Jacksonville, Florida 32207, but the Association may maintain offices and transact business in such places, within or without the State of Florida, as may from time to time be designated by the Board of Directors.

**ARTICLE VII**

**OFFICERS**

The affairs of the Association shall be managed by the President of the Association assisted by the Vice President(s), Secretary and Treasurer and, if any, the Assistant Secretaries and Assistant Treasurers, who shall perform the duties of such offices customarily performed by like officers of corporations in the State of Florida subject to the directions of the Board of Directors.

The Board of Directors shall elect a President, Secretary, Treasurer and as many Vice Presidents, Assistant Secretaries and Assistant Treasurers as the Board of Directors shall deem advisable from time to time. The President shall be elected from the membership of the Board of Directors, but no other officer need to be a Director. The same person may hold two offices, the duties of which are not incompatible; provided, however, that the office of the President and Vice President shall not be held by the same person, nor shall the office of President and Secretary or Assistant Secretary be held by the same person. Officers shall be elected annually.

The officers of the Association, who shall hold office until their successors are elected pursuant to these Articles of Incorporation and the Bylaws, and have qualified, shall be the following:

President & Treasurer	Henry Lorber
Vice President/Secretary	Tom Thoman

Officers of the Association may be compensated in the manner to be provided in the Bylaws. The Board of Directors, or the President with the approval of the Board of Directors, may employ a managing agent, agency and/or other managerial and supervisory personnel or entity to administer or assist in the administration of the operation and management of the Condominium and the affairs of the Association, and any and all such persons and/or entity or entities may be so employed without regard to whether any such person or entity is a member of the Association or a Director or officer of the Association, as the case may be.

## ARTICLE VIII

### DIRECTORS

The number of members of the Board of Directors shall be not less than three (3). The initial members of the Board of Directors shall be appointed by the Developer. When Unit Owners other than the Developer own 15 percent or more of the Units in the Condominium that will be operated ultimately by the Association, the Unit Owners other than the Developer shall be entitled to elect no less than one-third of the members of the Board of Directors of the Association. Unit Owners other than the Developer are entitled to elect not less than a majority of the members of the Board of Directors of the Association: Three years after 50 percent of the Units that will be operated ultimately by the Association have been conveyed to purchasers; Three months after 90 percent of the Units that will be operated ultimately by the Association have been conveyed to purchaser; When all the Units that will be operated ultimately by the Association have been completed, some of them have been conveyed to purchasers, and none of the others are being offered for sale by the Developer in the ordinary course of business; When some of the Units have been conveyed to purchasers and none of the others are being constructed or offered for sale by the Developer in the ordinary course of business; or seven years after recordation of the Declaration of Condominium, whichever occurs first. The Developer is entitled to elect at least one member of the Board of Directors of the Association as long as the Developer holds for sale in the ordinary course of business at least 5 percent of the Units in the Condominium operated by the Association. After Unit Owners other than the Developer elect a majority of the members of the Board of Directors, the Developer shall, within a reasonable time and in a manner to be provided in the Bylaws and the Act, relinquish control of the Association and shall deliver to the Association all property of the Unit Owners and the Association held or controlled by the Developer. Following the time the Developer



relinquishes control of the Association, the Developer may exercise the right to vote any Developer-owned Units in the same manner as any other Unit Owner except for purposes of reacquiring control of the Association or selecting the majority members of the Board of Directors. Meetings for the election of members of the Board of Directors shall be held annually, in a manner to be provided in the Bylaws.

The names and addresses of the members of the first Board of Directors who, subject to the provisions of the laws of Florida, these Articles of Incorporation and the Bylaws, shall hold office for the first year of the Association's corporate existence, and thereafter until their successors are elected and have qualified, are as follows:

Henry Lorber  
270 Carpenter Drive, Suite 200  
Atlanta, Georgia 30328

Tom Thoman  
270 Carpenter Drive, Suite 200  
Atlanta, Georgia 30328

Thomas M. Jenks, Esquire  
Pappas Metcalf Jenks & Miller, P.A.  
200 West Forsyth Street, Suite 1400  
Jacksonville, Florida 32202

## ARTICLE IX

### INCORPORATOR

The Incorporator under these Articles of Incorporation and his respective address, is set forth below:

Henry Lorber  
2043 Dunsford Terrace  
Jacksonville, Florida 32207

**ARTICLE X**

**BYLAWS**

The original Bylaws of the Association shall be adopted by a majority vote of the Board of Directors of the Association at a meeting at which a majority of the Board of Directors is present, and, thereafter, the Bylaws may be altered or rescinded only by affirmative vote of two-thirds (2/3) of the votes entitled to be cast by members of the Association.

**ARTICLE XI**

**INDEMNIFICATION**

Every Director and every officer of the Association shall be indemnified by the Association against all expenses and liabilities, including attorney's fees, reasonably incurred by or imposed upon him in connection with any proceeding to which he may be a party, or in which he may become involved, by reason of his being or having been a Director or officer of the Association, whether or not he is a Director or officer at the time such expenses are incurred, except in such cases wherein the Director or officer is adjudged guilty of willful misfeasance or malfeasance in the performance of his duties; provided, that in the event any claim for reimbursement or indemnification hereunder is based upon a settlement by the Director or officer seeking such reimbursement or indemnification, the indemnification herein shall only apply if the Board of Directors approves such settlement and reimbursement as being in the best interests of the Association. The foregoing right of indemnification shall be in addition to and not exclusive of all other rights to which such Director or officer may be entitled.

**ARTICLE XII**

**AMENDMENT TO ARTICLES**

An amendment or amendments to these Articles of Incorporation may be proposed by the Board of Directors of the Association acting upon a vote of the majority of the Directors, or by the members of the Association owning a majority of the Units in the Condominium, whether meeting as members or by instrument in writing signed by them. Upon any amendment or amendments to these Articles of Incorporation being proposed by the Board of Directors or members, such proposed amendment or amendments shall be adopted by a Resolution of the Board of Directors setting forth the proposed amendment and directing that it be submitted to a vote at an annual or special meeting of the members. Such resolution shall be transmitted to the President of the Association or the acting chief-executive officer in the absence of the President, who shall thereupon call a special meeting of the members of the Association for a date not sooner than twenty (20) days nor later than sixty

(60) days from the receipt by him of the Resolution containing the proposed amendment or amendments, and it shall be the duty of the Secretary to give each member written notice of such meeting stating the time and place of the meeting and reciting the proposed amendment or amendments in reasonably detailed form, which notice shall be mailed or presented personally to each member not less than ten (10) days nor more than thirty (30) days before the date set for such meeting. If mailed, such notice shall be deemed to be properly given when deposited in the United States mail, addressed to the member at his Post Office address as it appears on the records of the Association, with postage thereon prepaid. Any member may, by written waiver of notice signed by such member, waive such notice, and such waiver when filed in the records of the Association, whether before, during or after the holding of the meeting, shall be deemed equivalent to the giving of such notice to such member. At such meeting the amendment or amendments proposed must be approved by an affirmative vote of the members owning not less than a majority of the Units in the Condominium in order for such amendment or amendments to become effective. Thereupon, such amendment or amendments of these Articles of Incorporation shall be transcribed and certified in such form as may be necessary to file the same in the office of the Secretary of State of the State of Florida. A certified copy of each such amendment of these Articles of Incorporation shall be recorded in the public records of Duval County, Florida, within thirty (30) days from the date on which the same is filed in the office of the Secretary of State. Notwithstanding the foregoing provisions of this Article XII, no amendment to these Articles of Incorporation which shall abridge, amend or alter the right of Developer to designate and select members of the Board of Directors of the Association, as provided in Article VIII hereof, may be adopted or become effective without the prior written consent of Developer.

### ARTICLE XIII

#### DISSOLUTION OF THE ASSOCIATION

The Association may be dissolved in accordance with the provisions of the Declaration and in accordance with law. In the event of termination, dissolution or final liquidation of the Association, the responsibility for the operation and maintenance of the Surface Water or Stormwater Management System must be transferred to and accepted by an entity which would comply with Section 40C-42.027, Florida Administrative Code, and be approved by the District prior to such termination, dissolution or liquidation.



**CERTIFICATE OF DESIGNATING PLACE OF BUSINESS OR  
DOMICILE FOR THE SERVICE OF PROCESS WITHIN  
FLORIDA, NAMING AGENT UPON WHOM PROCESS MAY BE SERVED**

---

IN COMPLIANCE WITH SECTION 48.091, FLORIDA STATUTES, THE FOLLOWING IS SUBMITTED:

CITIHOMES AT SAN MARCO CONDOMINIUM ASSOCIATION, INC., DESIRING TO ORGANIZE OR QUALIFY UNDER THE LAWS OF THE STATE OF FLORIDA WITH ITS PRINCIPAL PLACE OF BUSINESS AT CITY OF JACKSONVILLE, STATE OF FLORIDA, HAS NAMED \_\_\_\_\_, AS ITS AGENT TO ACCEPT SERVICE OF PROCESS WITHIN FLORIDA.

**CITIHOMES AT SAN MARCO  
CONDOMINIUM ASSOCIATION, INC.,**  
a Florida corporation not-for-profit

By: \_\_\_\_\_  
**Tom Thoman**  
Incorporator

DATED: \_\_\_\_\_, 2001

HAVING BEEN NAMED TO ACCEPT SERVICE OF PROCESS FOR THE ABOVE STATED CORPORATION, AT THE PLACE DESIGNATED IN THIS CERTIFICATE, I HEREBY AGREE TO ACT IN THIS CAPACITY, AND I FURTHER AGREE TO COMPLY WITH THE PROVISIONS OF ALL STATUTES RELATIVE TO THE PROPER AND COMPLETE PERFORMANCE OF MY DUTIES.

\_\_\_\_\_  
\_\_\_\_\_  
Resident Agent

Dated: \_\_\_\_\_, 2001

EXHIBIT "F"

(Bylaws of Citihomes at San Marco  
Condominium Association)



BYLAWS

OF

**CITIHOMES AT SAN MARCO CONDOMINIUM ASSOCIATION, INC.**  
**a Florida corporation not-for-profit**

**I. IDENTITY**

A. These are the Bylaws of Citihomes at San Marco Condominium Association, Inc. ("Association") a Florida corporation not-for-profit. The purpose of the Association is the administration, operation and management of a condominium known as Citihomes at San Marco Condominium ("Condominium") as the same may now or hereafter be constituted, which Condominium is established in accordance with the Florida Condominium Act, Chapter 718, *Florida Statutes* ("Act"). The Association shall undertake the performance of and shall carry out the acts and duties incident to the administration, operation and management of the Condominium in accordance with the terms, provisions and authorizations contained herein, in the Articles of Incorporation of the Association ("Articles") and in the Declaration of Condominium which will be recorded in the public records of Duval County, Florida. In addition, the Association may own, operate, lease, sell, trade or otherwise deal with any property, real or personal, as may become part of the Condominium ("Condominium Property") and as may be necessary or convenient for the administration of the Condominium.

B. The provisions of these Bylaws are applicable to the Condominium and are subject to the provisions of the Articles. A copy of the Articles and a copy of these Bylaws will be annexed as exhibits to the Declaration of Condominium of the Condominium ("Declaration") which will be recorded in the public records of Duval County, Florida. The terms and provisions of the Articles and Declaration shall control wherever the same may conflict herewith.

C. All Members of the Association, as defined in the Articles, and their invitees, including, without limitation, all present or future owners and tenants of dwelling units in the Condominium ("Units") and other persons using the Condominium or any of the facilities thereof in any manner, are subject to these Bylaws, the Articles and the Declaration.

D. The office of the Association shall be at 2043 Dunsford Terrace, Jacksonville, Florida 32207, or at such other place as may be established by resolution of the Board of Directors.

E. The fiscal year of the Association shall be the calendar year.

F. The seal of the Association shall bear the name of the Association, the word "Florida", the words "Corporation Not-For-Profit" and the year of incorporation.

**II. MEMBERSHIP, VOTING, QUORUM, PROXIES**

A. The qualification of members of the Association ("Members"), the manner of their admission to the membership and termination of such membership and voting rights of Members ("Voting Interests") shall be as set forth in Article IV of the Articles, the provisions of which are incorporated herein by reference.

B. A quorum at meetings of Members shall consist of twenty-five percent (25%) of the Voting Interests represented either in person or by proxy.

C. The vote of the owner(s) of a Unit owned by more than one natural person, as tenants in common, joint tenants (except a husband and wife as tenants by the entirety) a partnership, or any other association of natural persons, or by a corporation, a trust, or any other entity shall be cast or otherwise exercised, at all meetings at which Members of the Association are entitled to vote or otherwise act, by one natural person designated by the owner(s) of such Unit as the "Primary Occupant" thereof. In each instance where title to a Unit is proposed to be conveyed or is otherwise to become vested in more than one natural person (except a husband and wife as tenants by the entirety) a partnership, or any Association of natural persons, or a corporation, a trust, or any other entity, the prospective owner(s) shall, by written instrument acceptable to the Association ("Voting Certificate") designate one natural person as the Primary Occupant. The Voting Certificate shall be filed with the Association and the person so designated shall be and remain the Primary Occupant of the Unit until such designation has been revoked by written instrument executed by the owner(s) of the Unit or by lawful conveyance of the Unit. The Primary Occupant of the Unit shall be the only person entitled to cast or exercise, in person or by proxy, the vote of the owner(s) of such Unit at any meeting of Members or in connection with any action concerning which Members of the Association shall be required or allowed to vote or otherwise act.

D. Evidence of the approval or disapproval of the owner(s) of a Unit upon any matter, whether or not the subject of an Association meeting, shall be given to the Association by the same person who would cast the vote of such owner if in an Association meeting.

E. Except as otherwise required under the provisions of the Articles, these Bylaws or the Declaration, or where the same otherwise may be required by law, at any meeting of the general membership of the Association, which is duly called and at which time a quorum is present, the affirmative vote of the majority of the Voting Interests present shall be binding upon the Members.

F. Except as otherwise required under the provisions of these Bylaws, at any meeting of the Members, every Member having the right to vote shall be entitled to vote in person or by general or limited proxy as provided by law. Any proxy given shall be effective only for the specific meeting for which originally given and any lawfully adjourned meetings thereof. In no event shall any proxy be valid for a period longer than ninety (90) days after the date of the first meeting for which it was given. Every proxy shall be revocable at any time at the pleasure of the Member executing it.

**III. ANNUAL AND SPECIAL MEETINGS OF MEMBERSHIP**

A. The annual meeting of the Members shall be held at the office of the Association or such other place in Duval County, Florida, and at such time as may be specified in the notice of the meeting, for the purposes of electing Directors and of transacting any other business authorized to be transacted by the Members.

B. Except as elsewhere provided in these Bylaws to the contrary, special meetings of the entire membership of the Association shall be held whenever called by the President or Vice-President or by a majority of the Board of Directors. A special meeting must be called by the officers upon receipt of a written request from Members of the Association owning a majority of the Voting Interests in the Condominium.

C. Notice of all meetings of Members, if any, shall be given by the Secretary or, in the absence of the Secretary, another officer of the Association, to each Member, if any (unless waived in writing). Each notice shall be written or printed and shall incorporate an identification of agenda items and shall state the time, place of and purpose for which the meeting is called. Notice of the Annual Meeting shall be given to each Member not less than fourteen (14) days nor more than sixty (60) days prior to the date set for the meeting, and shall be mailed to each Member. Such notice shall be deemed properly given when deposited in the United States Mail addressed to the Member at his Post Office address as it appears on the records of the Association, with postage thereon prepaid. An officer of the Association shall provide an affidavit, to be included in the official records of the Association, affirming that notices of the Association meeting were mailed in accordance with this provision, to each Unit owner at the address last furnished to the Association. Each notice shall in addition be posted at a conspicuous place in the Condominium at least fourteen (14) continuous days prior to said meeting. Upon notice to all Unit Owners, the Board shall by duly adopted rule designate a specific location on the Condominium Property, upon which all notices of Unit Owner meetings shall be posted. If any meeting of the Members cannot be held because a quorum is not present, or because a greater percentage of the Voting Interests required to constitute a quorum for a particular purpose is not present, wherever the latter percentage may be required as set forth in the Articles, the Bylaws or the Declaration, the Members who are present, either in person or by proxy, may

adjourn the meeting from time to time until a quorum, or the required percentage of attendance if greater than a quorum, is present.

D. At meetings of Members the President shall preside, or in his absence, the Vice President, or in the absence of both, the Members present shall select a chairman of the meeting. Minutes shall be kept in a businesslike manner and available for inspection by Directors, Members and their authorized representatives during normal business hours at the principal office of the Association. The Association shall retain these minutes for a period of not less than seven (7) years.

E. Any Unit owner may tape record or videotape meetings of the Board of Directors and meetings of Members. Unit Owners have the right to speak at meetings of the Board of Directors and meetings of Members with reference to all designated agenda items.

F. The order of business at annual meetings of Members, and, as far as practical, at other meetings of Members, shall be:

1. Calling of the roll and certifying of proxies
2. Proof of notice of meeting or waiver of notice
3. Reading or waiver of reading of minutes of previous meeting of Members
4. Reports of officers
5. Reports of committees
6. Appointment by Chairman of inspectors of election
7. Election of directors
8. Unfinished business
9. New business
10. Adjournment

G. Members representing twenty-five percent (25%) of the Voting Interests, present in person or by proxy, shall be necessary to and shall constitute a quorum at all meetings of Members for the transaction of business, except as otherwise provided by statute, the Articles or these Bylaws.

Except as is otherwise provided in these Bylaws, at any Members meeting, every Member having a right to vote shall be entitled to vote in person, or by limited proxy appointed by an instrument in writing subscribed by such Member.

**IV. BOARD OF DIRECTORS**

A. The first Board of Directors shall consist of three (3) persons. When Unit Owners other than the Developer own 15 percent or more of the Units in the Condominium that will be operated ultimately by the Association, the Unit Owners other than the Developer shall be entitled to elect no less than one-third of the members of the Board of Directors of the Association. Unit Owners other than the Developer are entitled to elect not less than a majority of the members of the Board of Directors of the Association: Three years after 50 percent of the Units that will be operated ultimately by the Association have been conveyed to purchasers; Three months after 90 percent of the Units that will be operated ultimately by the Association have been conveyed to purchaser; When all the Units that will be operated ultimately by the Association have been completed, some of them have been conveyed to purchasers, and none of the others are being offered for sale by the Developer in the ordinary course of business; When some of the Units have been conveyed to purchasers and none of the others are being constructed or offered for sale by the Developer in the ordinary course of business; or seven years after recordation of the Declaration of Condominium, whichever occurs first. The Developer is entitled to elect at least one member of the Board of Directors of the Association as long as the Developer holds for sale in the ordinary course of business at least 5 percent of the Units in the Condominium operated by the Association. After Unit Owners other than the Developer elect a majority of the members of the Board of Directors, the Developer shall, within a reasonable time and in a manner to be provided in the Bylaws and the Act, relinquish control of the Association and shall deliver to the Association all property of the Unit Owners and the Association held or controlled by the Developer. Following the time the Developer relinquishes control of the Association, the Developer may exercise the right to vote any Developer-owned Units in the same manner as any other Unit Owner except for purposes of reacquiring control of the Association or selecting the majority members of the Board of Directors.

B. Directors shall be elected in the following manner:

1. Commencing with the election of the first Board to succeed the Board comprised of the persons named in the Articles, Developer shall designate that number and the identity of the members of the Board which it shall be entitled to designate in accordance with the Articles and these Bylaws, and upon such designation by Developer, by written instrument presented to the meeting at which such election is held, the persons so designated by Developer shall be deemed and considered for all purposes Directors of the Association and shall thenceforth hold the



offices and perform the duties of such Directors until their successors shall have been elected or designated, as the case may be, and qualified in accordance with the provisions of these Bylaws.

2. For so long as the Developer shall retain the right to appoint at least one (1) member of the Board of Directors, all members of the Board of Directors whom Developer shall not be entitled to designate under these Bylaws shall be elected at large, by a plurality of the votes cast at the annual meeting of the general membership, immediately following designation of the members of the Board whom Developer shall be entitled to designate. Commencing after the Developer shall have lost or relinquished the right to appoint at least one (1) Director, the Directors shall be elected at large, by a plurality of the votes cast by the general membership at the meeting.

3. Not less than sixty (60) days before the scheduled election, the Association shall mail or deliver, whether by separate Association mailing or included in another Association mailing or delivery, to each Unit Owner entitled to a vote, the first notice of the date of the election. Any Unit Owner or other eligible person desiring to be a candidate for the Board of Administration must give written notice to the Association not less than forty (40) days before scheduled election. Together with the written notice and agenda required pursuant to Section 718.112(2)(d), subparagraph 2, the Association shall mail or deliver a second notice of the election to all Unit Owners entitled to vote therein, together with a ballot which shall list all candidates. Upon request of the candidate, the Association shall include an information sheet, no larger than 8½" X 11", which must be furnished by the candidate not less than thirty-five (35) days before the election, to be included with the mailing of the ballot, with the costs of mailing or delivery and copying to be borne by the Association. The Association has no liability for the contents of the information sheets prepared by the candidate. No Unit Owner shall permit any other person to vote his ballot, and any such ballot improperly cast shall be invalid. The regular election shall occur on the date of the annual meeting.

4. Vacancies on the Board may be filled to expire on the date of the next annual meeting by the remaining Directors except that, should any vacancy in the Board be created in a directorship previously filled by any person designated by Developer, such vacancy should be filled by Developer designating by written instrument delivered to any office of the Association, the successor Director, who shall fill the vacated directorship for the unexpired term thereof.

5. If, at the time of the first annual meeting of Members, Unit owners other than the Developer are entitled to elect some or all of the Directors, the terms of office of not more than two (2) such Directors receiving the highest plurality of votes shall be two (2) years, and the terms of office of the remaining Director or Directors elected by the next highest plurality of votes shall be one (1) year. If, at the time of the first annual meeting of Members, Developer is entitled to designate some or all of the Directors, Developer shall have the right to designate for two (2) year



terms that number of Directors which together with the Directors elected by other Unit owners, if any, total three (3) Directors. The remaining Director or Directors designated by the Developer, if any, shall have terms of office of one (1) year; the intention being that terms of office of Directors be staggered after the first annual meeting with up to three (3) Directors elected by Unit owners other than the Developer to serve the initial two (2) year terms. Thereafter, as many Directors shall be elected, or designated by Developer as the case may be, for two (2) year terms, as there are regular terms of office for Directors expiring at such times. Directors shall hold office for the terms to which elected or designated, and thereafter until their successors are duly elected, or designated by the Developer, and qualified, or until removed in the manner elsewhere herein provided or provided by law.

6. In the election of Directors, there shall be appurtenant to each Unit one (1) vote for each Director's position which is to be filled at that meeting; provided, however, that no Member or owner of any Voting Interest may cast more than one (1) vote per Unit or Voting Interest owned for any person nominated as a Director, it being the intent hereof that the voting of Directors shall be non-cumulative.

7. The election of Directors shall be by written ballot. Proxies shall not be used in electing Directors.

8. Within seventy-five (75) days after Unit owners other than the Developer are entitled to elect a member or members of the Board of Directors of the Association, the Association shall, as otherwise provided in accordance with the provisions of these Bylaws, call and give not less than sixty (60) days notice of an election for members of the Board. Such meeting may be called and the notice given by any Unit Owner if the Association fails to do so within the time prescribed herein. Election of such Directors by the Unit Owners shall be conducted in the manner provided in these Bylaws. Upon election of the first Unit Owner other than the Developer to the Board, the Developer shall forward to the Division of Florida Land Sales, Condominiums and Mobile Homes the name and mailing address of such Unit Owner member.

9. In the event that Developer selects any person or persons to serve on any Board, Developer shall have the absolute right at any time, in its sole discretion, to replace any such person or persons with another person or other persons to serve on the Board. Replacement of any person or persons designated by Developer to serve on any Board shall be made by written instrument delivered to any officer of the Association, which instrument shall specify the name or names of the person or persons designated as successor or successors to the persons so removed from the Board. The removal of any Director and designation of his successor shall be effective immediately upon delivery of such written instrument by Developer to any officer of the Association.

C. The organizational meeting of a newly elected or designated Board shall be held within thirty (30) days of their election or designation, and shall be noticed as required by this Article IV.

D. Regular meetings of the Board may be held at such time and place as shall be determined from time to time by a majority of the Directors. Notice of regular meetings shall be given to each Director, personally or by mail, telephone or telegram, at least seven (7) days prior to the day named for such meeting, unless notice is waived.

E. President and must be called by the Secretary at the written request of one-third (1/3) of the Directors. Not less than three (3) days notice of a special meeting shall be given to each Director, personally or by mail, telephone or telegram, which notice shall state the time, place and purpose of the meeting. Adequate notice to the Members of all meetings (regular and special) of the Board, or any committee thereof at which a quorum of the members of that committee are present, shall be posted conspicuously on the Condominium Property at least forty-eight (48) continuous hours in advance of the meeting, except in an emergency. The notice shall specifically incorporate an identification of agenda items. Upon prior notice to all Unit Owners, the Board shall by duly adopted rule designate a specific location on the Condominium Property upon which notices of all Board meetings shall be posted. All meetings of the Board shall be open to all Unit Owners. Notice of any meeting of the Board or any committee thereof where the Association's budget or where regular assessments against Unit owners are to be considered for any reason shall specifically contain a statement that assessments will be considered and the nature of any such assessments. Written notice of any meeting of the Board or any committee thereof at which non-emergency special assessments, or at which amendment to rules regarding Unit use will be proposed, discussed, or approved, shall be mailed or delivered to the Members and posted conspicuously on the Condominium Property not less than fourteen (14) continuous days prior to the meeting. The Secretary of the Association shall provide an Affidavit, to be included in the official records of the Association, confirming that notice of such meeting was provided in accordance with this provision, to each Unit Owner.

F. Minutes of all meetings of the Board shall be kept in a businesslike manner and available for inspection by Members and Directors during normal business hours at the principal office of the Association. The Association shall retain these minutes for a period of not less than seven (7) years.

G. Any Director may waive notice of a meeting before, at or after the meeting by signing a waiver of notice and placing it in the minute book, and such waiver shall be deemed equivalent to the giving of notice.

H. A quorum at meetings of the Board shall consist of the Directors entitled to cast a majority of the votes of the entire Board. The acts of the Board approved by a majority of the votes present at a meeting at which a quorum is present shall constitute the acts of the Board of Directors, except as may be specifically otherwise provided in the Articles, these Bylaws or the Declaration. A Director of the Association who is present at a meeting of the Board at which action on any Association matter is taken shall be presumed to have assented to the Action taken, unless he votes against such action or abstains from voting in respect thereto because of an asserted conflict of interest. If any meeting of the Board cannot be held because a quorum is not present, or because the greater percentage of the Directors required to constitute a quorum for particular purposes is not present, wherever the latter percentage of attendance may be required as set forth in the Articles, these Bylaws or the Declaration, the Directors who are present may adjourn the meeting from time to time until a quorum, or the required percentage of attendance if greater than a quorum, is present. At any adjourned meeting, any business which might have been transacted at the meeting as originally called may be transacted without further notice to the Directors, however notice of the adjourned meeting must be given in accordance with Paragraph G, Article III and Paragraph E, Article IV hereof. All meetings of the Board of Directors shall be open to all Unit Owners, unless otherwise provided by law.

I. The presiding officer of meetings of the Board shall be the President of the Association. In the absence of the presiding officer, the Directors present shall designate one of their number to preside.

J. All of the powers and duties of the Association shall be exercised by the Board, including those existing under the laws of Florida, the Articles, these Bylaws and the Declaration. Such powers and duties shall be exercised in accordance with the Articles, these Bylaws and the Declaration, and shall include, without limitation, the right, power and authority to:

1. Make, levy and collect assessments, including without limitation, assessments for reserves and for improvements to Condominium Property, against Members and Members' Units to defray the costs of the Condominium, and use the proceeds of assessments in the exercise of the powers and duties of the Association;
2. Maintain, repair, replace, operate and manage the Condominium wherever the same is required to be done and accomplished by the Association for the benefit of Members;
3. Repair and reconstruct improvements after casualty;

4. Make and amend regulations governing the use of the property, real and personal, in the Condominium, provided that such regulations or amendments thereto shall not conflict with the restrictions and limitations which may be placed upon the use of such property under the terms of the Articles and Declaration;

5. Acquire, own, hold, operate, lease, encumber, convey, exchange, manage and otherwise trade and deal with property, real and personal, including Units of and in the Condominium as may be necessary or convenient in the operation and management of the Condominium and in accomplishing the purposes set forth in the Declaration;

6. Contract for the management and maintenance of the Condominium Property and to authorize a management agent to assist the Association in carrying out its powers and duties including, but not limited to, the performance of such functions as the submission of proposals, collection of assessments, preparation of records, enforcement of rules and maintenance, repair and replacement of the common elements with funds as shall be made available by the Association for such purposes. The Association and its officers shall, however, retain at all times the powers and duties granted by the Condominium documents and the Condominium Act including, but not limited to, the making of assessments, promulgation of rules and execution of contracts on behalf of the Association;

7. Enforce by legal means the provisions of the Articles, these Bylaws, the Declaration and all regulations governing use or property of and in the Condominium hereafter adopted;

8. Pay all taxes and assessments which are liens against any part of the Condominium other than Units and the appurtenances thereto, and assess the same against the Members and their respective Units subject to such liens;

9. Carry insurance for the protection of Members and the Association against casualty and liability;

10. Pay all costs of power, water, sewer and other utility services rendered to the Condominium and not billed to the owners of the separate Units; and

11. Employ personnel for reasonable compensation to perform the services required for proper administration of the purposes of the Association.

K. The first Board of Directors of the Association shall be comprised of those Members of the Board as described in the Articles, who shall serve until their successors are designated by Developer or elected at the first annual meeting of the Members. Should any member of the First Board be unable to serve for any reason, the Developer shall have the right to select and designate a successor to act and serve for the unexpired term of the Director who is unable to serve.

L. Any member of the Board may be recalled and removed from office with or without cause by the vote or agreement in writing by a majority of all Voting Interests. A special meeting of the Members to recall a member or members of the Board may be called by ten percent (10%) of the Voting Interests giving notice of the meeting in the same manner as notice of the call of a special meeting of the Members is required as set forth in Article IV, Paragraph C, and the notice shall state the purpose of the meeting. Such special meeting to recall a member or members of the Board is subject, however to the right of Developer to elect Directors as provided herein.

1. If the recall is approved by a majority of all Voting Interests by a vote at a meeting, the recall will be effective as provided herein. The Board shall duly notice and hold a Board meeting within five (5) full business days of the adjournment of the Unit Owner meeting to recall one or more Board members. At the meeting, the Board shall either certify the recall, in which case such member or members shall be recalled effective immediately and shall turn over to the Board, within five (5) full business days, any and all records and property of the Association in their possession or shall proceed as set forth below.

2. If the proposed recall is by an agreement in writing by a majority of all Voting Interests, the agreement in writing or a copy thereof shall be served on the Association by certified mail or by personal service in the manner authorized by Chapter 47, *Florida Statutes*, and the Florida Rules of Civil Procedure. The Board shall duly notice and hold a meeting of the Board within five (5) full business days after receipt of the agreement in writing. At the meeting, the Board shall either certify the written agreement to recall a member or members of the Board, in which case such member or members shall be recalled effective immediately and shall turn over to the board, within five (5) full business days, any and all records and property of the Association in their possession or proceed as described below.

3. If the Board determines not to certify the written agreement to recall a member or members of the Board or does not certify the recall by a vote at a meeting the Board shall, within five (5) full business days after the meeting, file with the Division of Florida Land Sales, Condominiums and Mobile Homes ("Division") a petition for arbitration pursuant to the procedures in Section 718.1255, *Florida Statutes*. For the purposes of this provision, the Unit owners who voted at the meeting or who executed the agreement in writing shall constitute one party under the petition for arbitration. If the arbitrator certifies the recall as to any member or members of the Board, the



recall will be effective upon mailing of the final order of arbitration to the Association. If the Association fails to comply with the order of the arbitrator, the Division may take action pursuant to Section 718.501, *Florida Statutes*. Any member or members so recalled shall deliver to the Board any and all records of the Association in their possession within five (5) full business days of the effective date of the recall.

4. If the Board fails to duly notice and hold a Board meeting within five (5) full business days of service of an agreement in writing or within five (5) full business days of the adjournment of the Unit owner recall meeting, the recall shall be deemed effective and the Board members so recalled shall immediately turn over to the Board any and all records and property of the Association.

5. If a vacancy occurs on the Board as a result of a recall and less than a majority of the Board members are removed, the vacancy may be filled by the affirmative vote of a majority of the remaining Directors, notwithstanding any provision to the contrary contained in this Paragraph L. If vacancies occur on the Board as a result of a recall and a majority or more of the Board members are removed, the vacancies shall be filled in accordance with procedural rules to be adopted by the Division, which rules need not be consistent with this Paragraph L. The rules must provide procedures governing the conduct of the recall election as well as the operation of the Association during the period after a recall, but prior to the recall election.

M. Notwithstanding anything contained in these Bylaws to the contrary, any meeting of members of the Board may be held at any place, within or without the State of Florida, designated in the notice of any such meeting, or notice of which is waived.

## V. OFFICERS

A. The Board shall elect a President, Secretary, Treasurer and as many Vice Presidents, Assistant Secretaries and Assistant Treasurers as the Board shall deem advisable from time to time. The President shall be elected from the membership of the Board, but no other officer need be a Director. The same person may hold two (2) offices, the duties of which are not incompatible; provided, however, that the office of President and Vice President shall not be held by the same person, nor shall the office of President and Secretary or Assistant Secretary be held by the same person. The Board may from time to time elect such other officers, and designate their powers and duties, as the Board may deem necessary to properly manage the affairs of the Association. Officers may be removed from office by the Board.



B. The President shall be the chief executive officer of the Association. He shall have all of the powers and duties which are usually vested in the office of President of a corporation not-for-profit including, but not limited to, the power to appoint committees from among the Members from time to time, as he may in his discretion determine appropriate, to assist in the conduct of the affairs of the Association. He shall have such additional powers as the Board may designate.

C. The Vice President shall, in the absence or disability of the President, exercise the powers and perform the duties of President. He shall also generally assist the President and exercise such other powers and perform such other duties as shall be prescribed by the Board.

D. The Secretary shall keep the minutes of all proceedings of the Board and the Members. He shall attend to the giving and serving of all notices to the Members and the Board, and such other notices as may be required by law. He shall have custody of the seal of the Association and affix the same to instruments requiring a seal when duly signed. He shall keep the records of the Association, except those of the Treasurer, and shall perform all other duties incident to the office of Secretary of a corporation not-for-profit and as may be required by the Board and the President. The Assistant Secretary shall perform the duties of Secretary when the Secretary is absent.

E. The Treasurer shall have custody of all of the Property of the Association including funds, securities and evidences of indebtedness. He shall keep the assessment roll and accounts of the Members; he shall keep the books of the Association in accordance with good accounting practices, and he shall perform all other duties incident to the office of Treasurer.

F. The compensation of all officers and employees of the Association shall be fixed by the Board. This provision shall not preclude the Board from employing a Director as an employee of the Association, nor preclude contracting with a Director for the management of the Condominium.

## **VI. FIDELITY BONDING OF OFFICERS AND DIRECTORS**

The Association shall obtain and maintain adequate insurance or fidelity bonds for all persons who control or disburse funds for the Association. The insurance policy or fidelity bond must cover the maximum funds that will be in the custody of the Association or its management agent at any one time. The Association shall bear the cost of bonding.

**VII. OFFICIAL RECORDS**

A. From the inception of the Association, the Association shall maintain a copy of each of the following where applicable, which shall constitute the official records of the Association;

1. The plans, permits, warranties and other items provided by the Developer applicable to the Condominium;
2. A photocopy of the recorded Declaration and all amendments thereto;
3. A photocopy of these Bylaws as recorded and all amendments thereto;
4. A certified copy of the Articles and amendments thereto;
5. A copy of the current Rules and Regulations of the Association;
6. The Association minute book containing the minutes of all meetings of the Association, of the Board, and of Unit owners, which minutes shall be retained for a period of not less than seven (7) years;
7. A current roster of all Unit owners, their mailing addresses, Unit identifications, Voting Certificates, and if known, telephone numbers;
8. All current insurance policies of the Association and the Condominium;
9. A current copy of any management agreement, lease, or other contract to which the Association is a party or under which the Association or the Unit owners have an obligation or responsibility;
10. Bills of sale or transfer for all property owned by the Association;
11. Accounting records for the Association maintained according to good accounting practices. All accounting records shall be maintained for a period of not less than seven (7) years. The accounting records shall include, but are not limited to:
  - (a) Accurate, itemized, and detailed records of all receipts and expenditures.

(b) A current account and a monthly, bimonthly or quarterly statement of the account for each Unit designating the name of the Unit owner, the due date and amount of each assessment, the amount paid upon the account, and the balance due.

(c) All audits, reviews, accounting statements and financial reports of the Association or Condominium.

(d) All contracts for work to be performed. Bids for work to be performed shall also be considered official records and shall be maintained for a period of one (1) year.

12. Voting proxies, which shall be maintained for a period of one (1) year from the date of the meeting for which the proxy was given.

13. All rental records where the Association is acting as agent for the rental of Condominium Units.

B. The official records of the Association shall be maintained in Duval County, Florida.

C. The official records of the Association shall be open to inspection by any Association member or the authorized representative of such member at all reasonable times.

### **VIII. FISCAL MANAGEMENT**

The provisions for fiscal management of the Association set forth in the Declaration and Articles shall be supplemented by the following provisions:

A. The assessment roll shall be maintained in a set of accounting books in which there shall be an account for each Unit. Such account shall designate the name and mailing address of the owner(s) of each Unit, the amount of each assessment against the owner(s) of each Unit, the amount paid, and the balance due upon each assessment.

B. The Board shall adopt for, and in advance of, each fiscal year, a budget for the Condominium showing the estimated costs of performing all of the functions of the Association as such Condominium for the year. The budget shall show the total estimated expenses of the Association for that year and shall contain an itemized breakdown of the Common Expenses, which shall include, without limitation, the costs of operating and maintaining the Common Elements and Limited Common Elements, taxes on Association property, wages and salaries of Association employees, management, legal and accounting fees, office supplies, public utility services not metered or charged separately to Units, premiums for insurance carried by the Association and

reserve accounts and/or funds which may be established from time to time by the Board as provided in the Declaration. Each budget shall also show the proportionate share of the total estimated expenses to be assessed against and collected from the owner(s) of each Unit and due date(s) and amount of installments thereof. Copies of the proposed budget and proposed assessments shall be transmitted to each Member on or before January 1 of the year for which the budget is made. If any budget is subsequently amended, a copy shall be furnished to each affected Member. Delivery of a copy of any budget or amended budget to a Member shall not affect the liability of any Member for any such assessment, nor shall delivery of a copy of such budget or amended budget be considered as a condition precedent to the effectiveness of the budget and assessments levied pursuant thereto. Nothing herein contained shall be construed as a limitation upon the additional assessment in the event that any budget originally adopted shall appear to be insufficient to pay costs and expenses of operation and management or in the event of emergencies.

C. A copy of the proposed annual budget of the Association shall be mailed or hand delivered to each Member at the address last furnished to the Association not less than fourteen (14) days prior to the meeting of the Board at which the budget will be considered, together with a notice of the time and place of that meeting. The Secretary of the Association shall provide an Affidavit, to be included in the official records of the Association, confirming that notice of such meeting was provided in accordance with this provision to each Unit owner. Such meeting of the Board shall be open to Members. If a budget is adopted by the Board which requires assessment of the Members in any budget year exceeding one hundred fifteen percent (115%) of such assessments for the preceding budget year, upon written application of ten percent (10%) of the Voting Interests, a special meeting of the Members shall be held upon not less than ten (10) days written notice to each Member, but within thirty (30) days of the delivery of such application to the Board or any member thereof, at which special meeting Members shall consider and adopt a budget. Any such budget shall require a vote of not less than two-thirds (2/3) of the whole number of all Voting Interests. The Board may in any event first propose a budget to the Members at any such meeting of Members or by writing, and if such budget or proposed budget be approved by a majority of the whole number of all Voting Interests, either at such meeting or by writing, such budget shall be adopted and shall not thereafter be reexamined by the Members in the manner hereinabove set forth. If a meeting of the Unit owners has been called pursuant to this provision and a quorum is not attained or a substitute budget is not adopted by the Unit owners, the budget adopted by the Board shall go into effect as scheduled.

D. In determining whether assessments exceed one hundred fifteen percent (115%) of similar assessments in the prior budget year, there shall be excluded from the computation reasonable reserves made by the Board for repair and replacement of Condominium Property; anticipated expenses by the Association which are not anticipated to be incurred on a regular or annual basis; and assessments for improvements to the Condominium Property. Provided, however,

that so long as Developer is in control of the Board of Directors, the Board shall not impose an assessment for a budget year greater than one hundred fifteen (115%) of the prior budget year's assessment without approval of a majority of the whole number of all Voting Interests.

E. Upon adoption of budgets, the Board shall cause written copy thereof to be delivered to all Members. Assessments shall be made against the Units pursuant to procedures established by the Board, and in accordance with terms of the Declaration and Articles. Members shall be liable to pay assessments not less often than quarterly. Provided, however, that the lien or lien rights of the Association shall not be impaired by failure to comply with procedures established pursuant to these Bylaws.

F. To provide funds necessary for proper operation and management of the Condominium, the Association shall have the right to make, levy and collect assessments against the Members and their respective Units to pay their share of Common Expenses. Assessments by the Association against each Member and his Unit shall be the fractional share of the total assessments to be made against all Members and their Units as set forth in the Declaration.

G. The specific purpose or purposes of any special assessment imposed by the Board shall be set forth in a written notice of such assessment sent or delivered to each Unit owner in the manner prescribed for giving notice of meetings to the Unit owners as described in these Bylaws. The funds collected pursuant to a special assessment shall be used only for the specific purpose or purposes set forth in such notice, or returned to the Unit owners. However, upon completion of such specific purpose or purposes, any excess funds shall be considered common surplus.

H. All sums collected by the Association from all assessments against all Units in the Condominium may be commingled in a single fund, or divided into more than one fund, as determined from time to time by the Board of Directors; provided, however, that reserve and operating funds of the Association shall not be commingled but shall be maintained in separate accounts at all times.

**IX. PARLIAMENTARY RULES AND ARBITRATION**

A. Roberts' Rules of Order (latest edition) shall govern the conduct of corporation proceedings when not in conflict with the Articles, these Bylaws or the laws of Florida.

B. Internal disputes arising from the operation of the Condominium among Unit owners, the Association, their agents and assigns shall be subject to mandatory non-binding arbitration as provided in *Florida Statutes*, Section 718.1255.



**X. AMENDMENTS TO BYLAWS**

Amendments to these Bylaws shall be proposed and adopted in the following manner:

A. Amendments to these Bylaws may be proposed by the Board, action upon vote of a majority of the Directors, or by members owning a majority of the Voting Interests in the Condominium, whether meeting as Members or by instrument in writing signed by them.

B. Upon any amendment or amendments to these Bylaws being proposed by the Board or Members, such proposed amendment or amendments shall be transmitted to the President of the Association or acting chief executive officer in the absence of the President, who shall thereupon call a special meeting of the Members for a date not sooner than twenty (20) days or later than sixty (60) days from receipt by such officer of the proposed amendment or amendments and it shall be the duty of the Secretary to give each Member written or printed notice of such meeting in the same form and in the same manner as notice of the call of a special meeting of the members is required as herein set forth; provided, that proposed amendments to the Bylaws may be considered and voted upon at annual meetings of the Members.

C. No Bylaw shall be revised or amended by reference to its title or number only. Proposals to amend existing Bylaws shall contain the full text of the Bylaws to be amended; new words shall be inserted in the text underlined, and words to be deleted shall be lined through with hyphens. However, if the proposed change is so extensive that this procedure would hinder, rather than assist, the understanding of the proposed amendment, it is not necessary to use underlining and hyphens as indicator of words added or deleted, but, instead, a notation must be inserted immediately preceding the proposed amendment in substantially the following language: "Substantial rewording of bylaw. See bylaw for present text." Nonmaterial errors or omissions in the bylaw process shall not invalidate an otherwise properly promulgated amendment.

D. In order for such amendment or amendments to become effective, the same must be approved by an affirmative vote of Members owning not less than two-thirds (2/3) of the Voting Interests in the Condominium. Thereupon, such amendment or amendments to these Bylaws shall be transcribed and shall include on the first page thereof a reference to the book and page of the public records where the Declaration is recorded, and shall be certified by the President and Secretary of the Association. A copy thereof shall be recorded in the public records of Duval County, Florida, within fifteen (15) days from the date on which any amendment or amendments have been affirmatively approved by the Members.



E. At any meeting held to consider such amendment or amendments to these Bylaws, the written vote of any Member shall be recognized if such Member is not present at such meeting in person or by limited proxy, provided such written vote is delivered to the Secretary at or prior to such meeting.

F. Notwithstanding the foregoing provisions of this Article X, no amendment to these Bylaws which shall abridge, amend or alter the rights of Developer may be adopted to become effective without the prior written consent of Developer. Notwithstanding the provisions contained herein for amendment to the Bylaws, no amendment to these Bylaws shall:

1. Change any "Condominium parcel" (as defined in the Act) unless the record owner thereof and all record owners of liens thereon shall join in the execution and acknowledgment of the amendment;

2. Discriminate against any Unit owner or against any Unit or building or class of buildings comprising part of the Condominium Property, unless the record owners of all affected Units and record owners of all liens thereon shall join in the execution and acknowledgment of the amendment;

3. Change the share of Common Elements appurtenant to any Unit or Units or the share of any Unit owner in the Common Surplus, or increase the share of any Unit owner(s) in the Common Expenses, unless the record owner of all Units and record owners of all liens thereon shall join in the execution and acknowledgment of such amendments; and

4. Adversely affect the lien or priority or materially and adversely affect the rights and remedies of any first mortgagee of any Unit or of mortgagees holding liens on five (5) or more Units by virtue of any previously recorded mortgage on a Unit to an Institutional Lender as defined in the Declaration, unless the record owner of all liens on the Units affected shall join in the execution and acknowledgment of the amendment.

## **XI. CERTIFICATE OF COMPLIANCE**

A certificate of compliance from a licensed electrical contractor or electrician may be accepted by the Board as evidence of compliance of the Units with applicable fire and life safety codes.

The foregoing were adopted as the Bylaws of Citihomes at San Marco Condominium Association, Inc., a corporation not-for-profit under the laws of the State of Florida, at the organizational meeting of the Board of Directors on the \_\_\_\_ day of \_\_\_\_\_, 2001.

\_\_\_\_\_  
Print Name \_\_\_\_\_  
Secretary